

# STABILA®

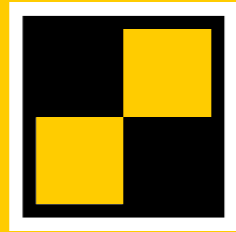

How true pro's measure

# REC 500 RG

Operating instructions

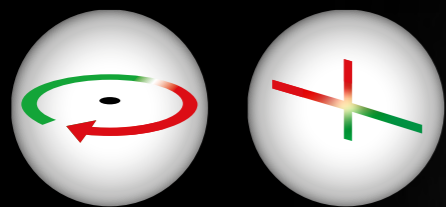

RED / GREEN BEAM



**Contents**

Section	Page
• 1 Intended use	3
• 2 Safety information	3
• 3 Components of the unit	4
• 4 Display elements	5
• 5 Commissioning	6
• 5.1 Battery insertion/replacement	6
• 5.2 Switching the unit on	6
• 5.3 Setting rotation/line mode	6
• 5.4 Setting optical guidance	7
• 5.5 Setting acoustic guidance	7
• 5.6 Adjusting the accuracy	7
• 6 Functions	8
• 6.1 Visual guidance	8
• 6.2 Acoustic guidance	8
• 6.3 Positioning and aligning the receiver	8
• 6.4 Retaining bracket	9
• 7 Technical data	10

## 1 Intended use

Congratulations on the purchase of your STABILA measuring tool. The STABILA REC 500 RG is an easy-to-use receiver for quickly locating red or green laser beams. The receiver functions with both pulse-modulated line lasers as well as rotation lasers.

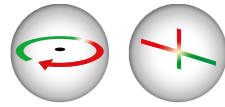

RED/GREEN BEAM

 If you still have questions after reading through the operating instructions, you can obtain advice by telephone:

 +49 63 46 3 09 0

### Equipment and functions:

- Quick location of pulse-modulated laser lines or rotating laser beams
- Suitable for red or green laser beams
- Housing protected in accordance with IP 67
- Adjustable accuracy
- Displays on front and rear
- Acoustic guidance can be activated
- LED display can be activated
- 1 vial for horizontal alignment
- Integrated magnet system for attachment to metal objects
- Retaining bracket for mounting the receiver on levelling rods
- Battery for operation

## 2 Safety information

Read the safety instructions and operating instructions through carefully.



### 3 Components of the unit

**REC 500 RG**  
(protected against water and dust in accordance with IP 67)

- (1) Magnet
- (2) Display – 1x on front, 1x on rear
- (3) LED mode display
- (4) Laser receiver
- (5) “On line” marking
- (6) Vial
- (7) Retaining bracket mounting area
- (8) Loudspeaker
- (9) Battery compartment lid

Buttons:



- (10) - On/Off
- Acoustic guidance

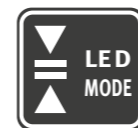

- (11) - Accuracy
- LED mode

- (12) Retaining bracket

- (13) Reading reference

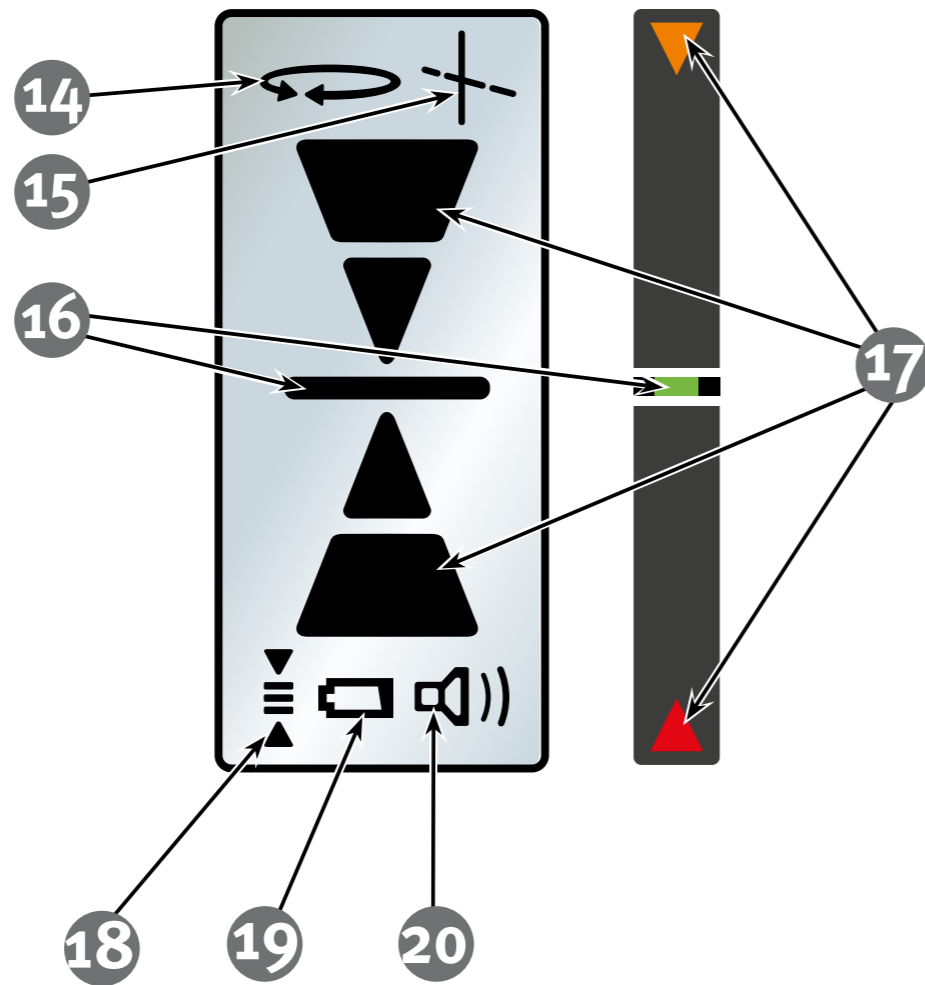

#### 4 Display elements

- (14) Rotation mode display
- (15) Line mode display
- (16) "On line" position
- (17) Display levels for height difference in relation to "On line" position
- (18) 4-level accuracy adjustment
- (19) Battery charge
- (20) Acoustic guidance

5 Commissioning

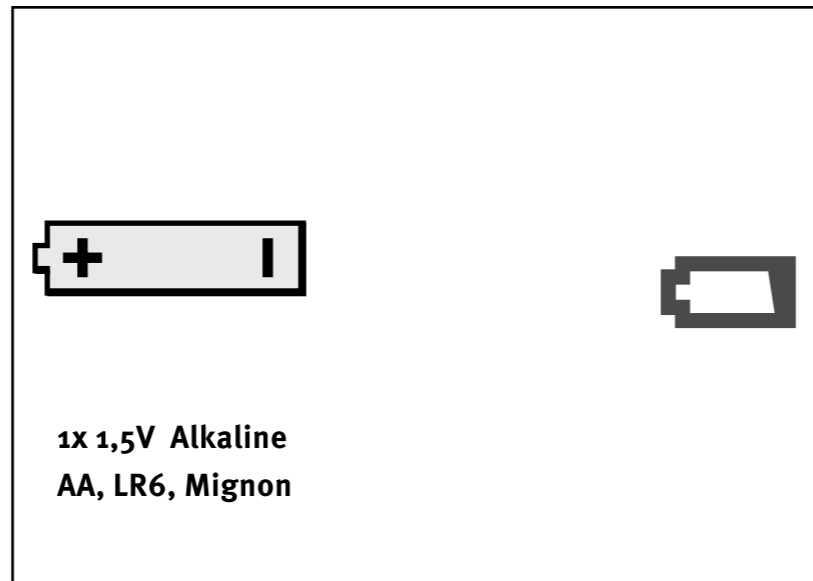
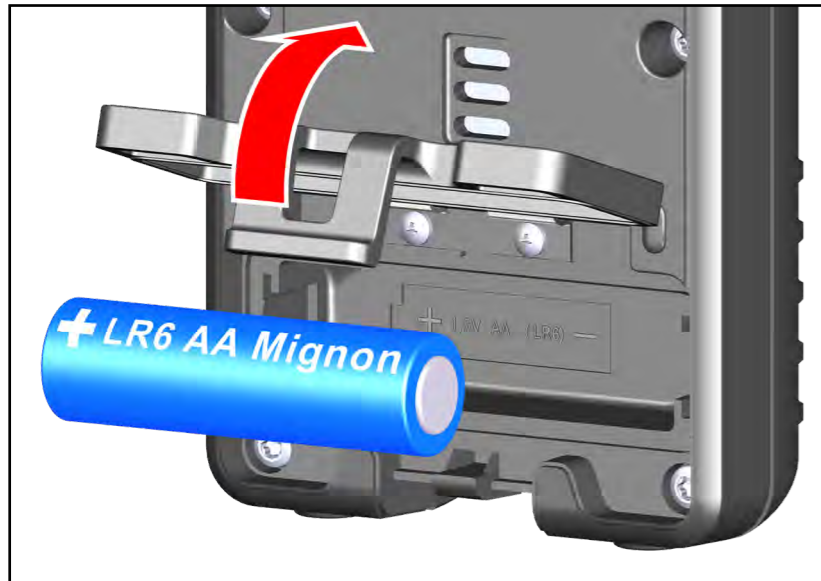

5.1 Battery insertion/replacement

Open the battery compartment cover in the direction of the arrow, insert the new battery into the battery compartment according to the symbol. Suitable rechargeable batteries can also be used.

LCD indicator:

- Insert the new battery



Used batteries should be disposed of at appropriate collection points. Do not dispose of in household waste. Do not leave in unit!

If you do not intend to use the unit for an extended period, remove the batteries.

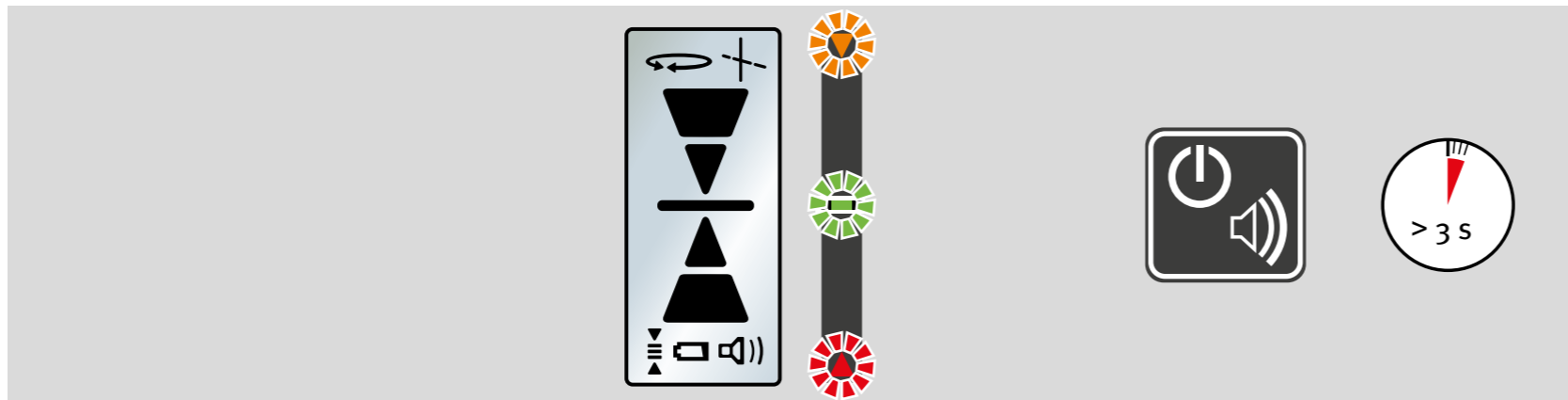

5.2 Switching the unit on

After switching on the unit using the ON/OFF button, all the display's segments are shown briefly. An acoustic signal sounds and the display lights up briefly to confirm that the unit is operational. Hold down the ON/OFF button (> 3 s) to switch off the unit.

The unit switches off automatically if it is not used for 30 minutes.

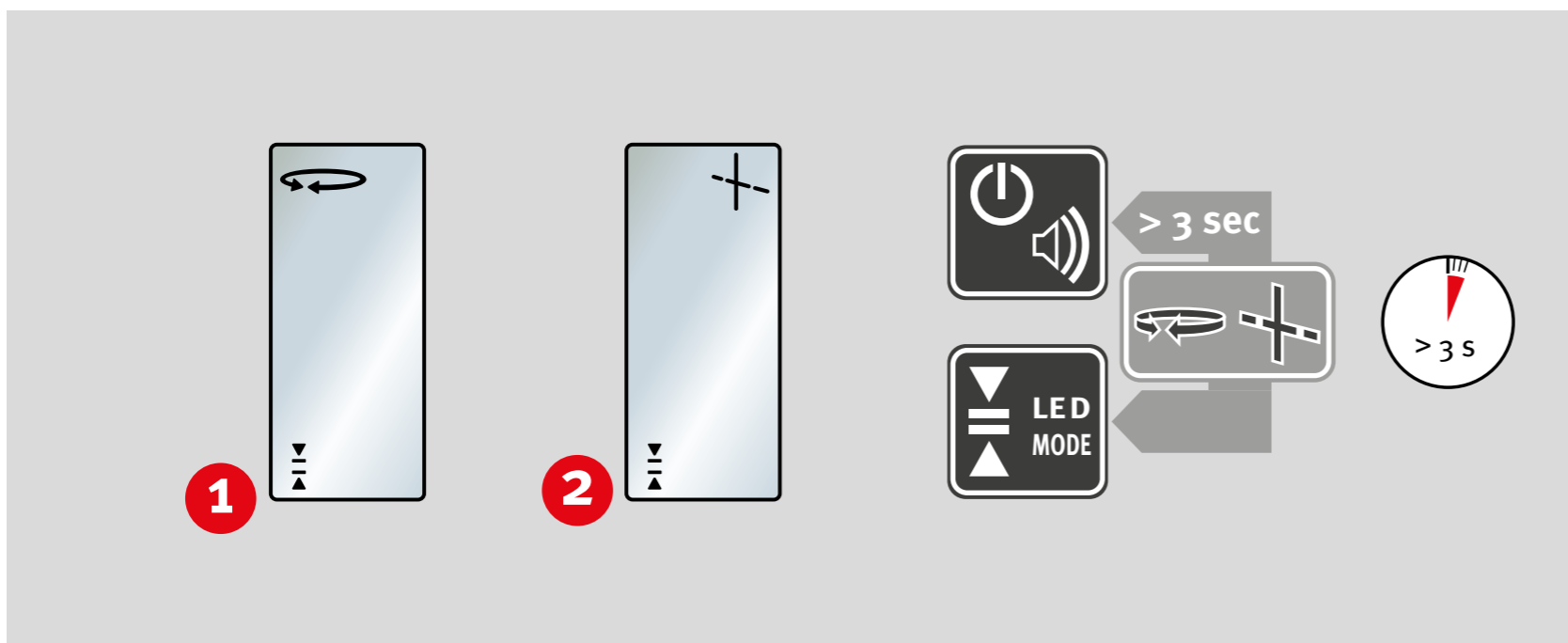

5.3 Setting rotation/line mode

Pressing both buttons at the same time switches between rotation and line mode. The previous setting is retained after the unit is switched off.

1 Rotation mode

2 Line mode

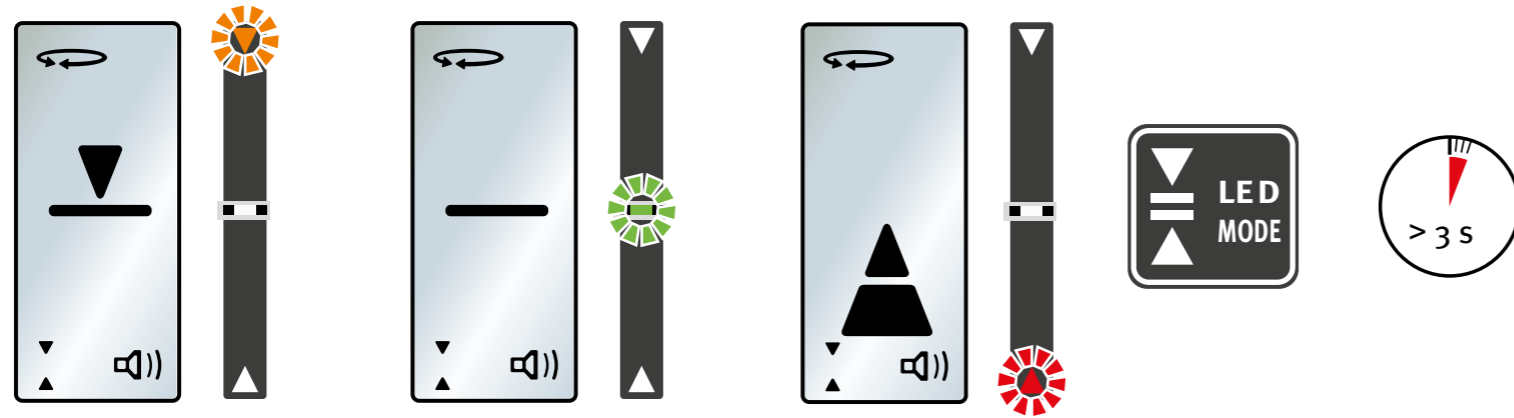

## 5.4 Setting optical guidance

Holding the button for longer switches LED mode on or off. Visibility at greater distances or in lower levels of light can be improved using the LED display.

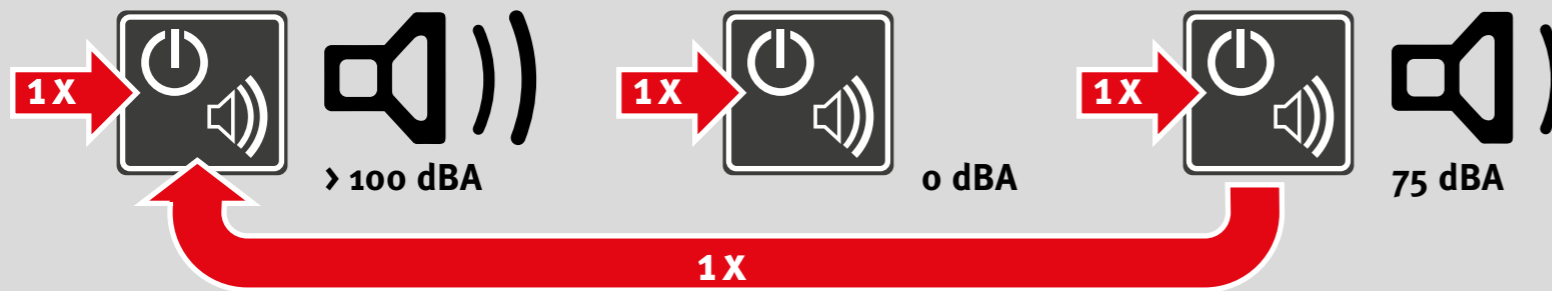

## 5.5 Setting acoustic guidance

The “Acoustic guidance” button can be used to set the volume.

The options are loud, off or soft.

If the sound is turned off, only a short beep sounds to indicate when the laser beam is being received. The previous setting is retained after the unit is switched off.

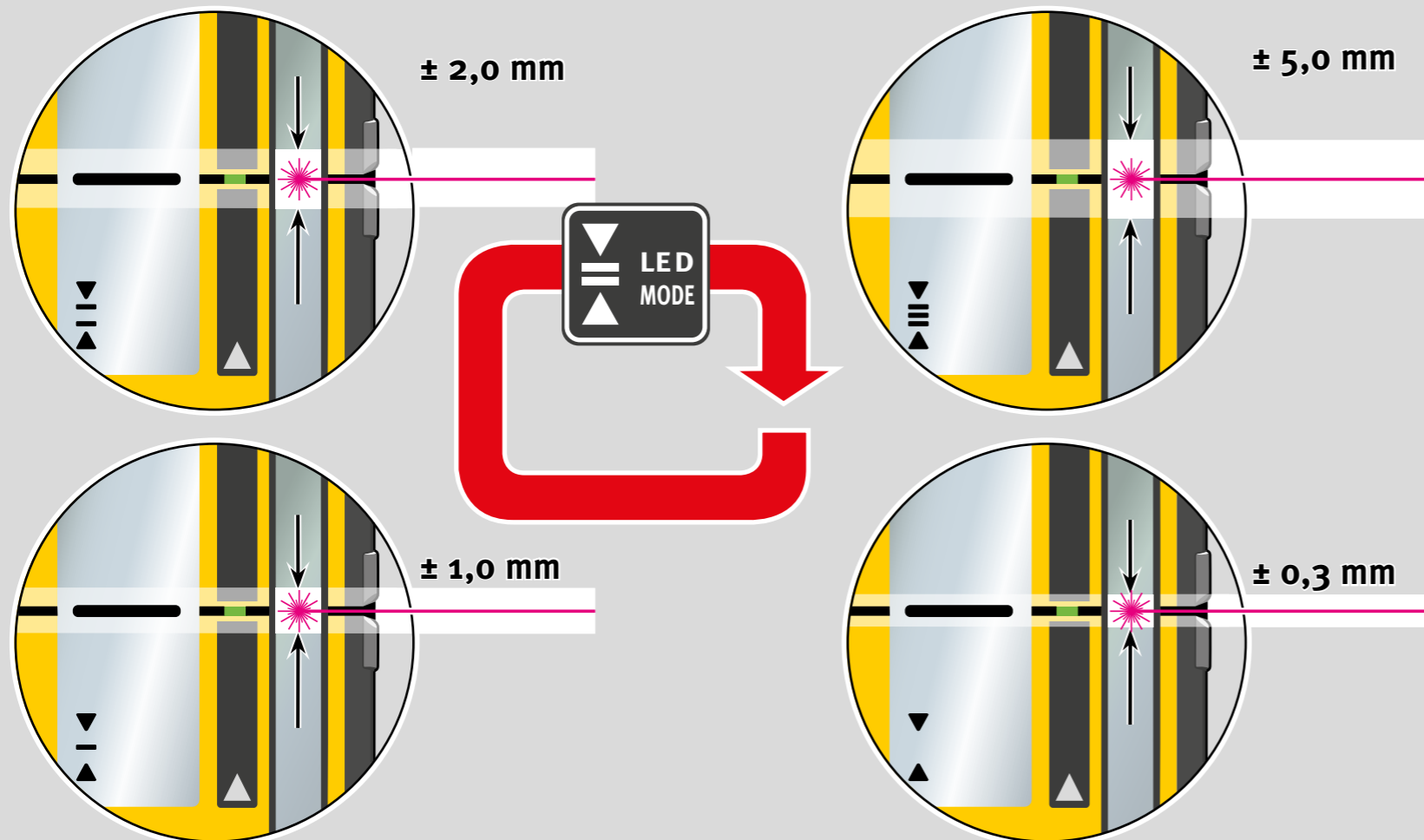

## 5.6 Adjusting the accuracy

Press the “Accuracy” button briefly and repeatedly to select the accuracy: “very fine” = ± 0.3 mm, “fine” = ± 1.0 mm (± 1/25 ’), “rough” = ± 2.0 mm and “very rough” = ± 5.0 mm. The previous setting is retained after the unit is switched off.

## 6 Functions

### 6.1 Visual guidance

#### Height difference display

The arrows indicate whether the receiver is too high or too low in relation to the laser beam. The line in the middle indicates the "On line" position of the receiver. In LED mode, 3 coloured LEDs also indicate the position.

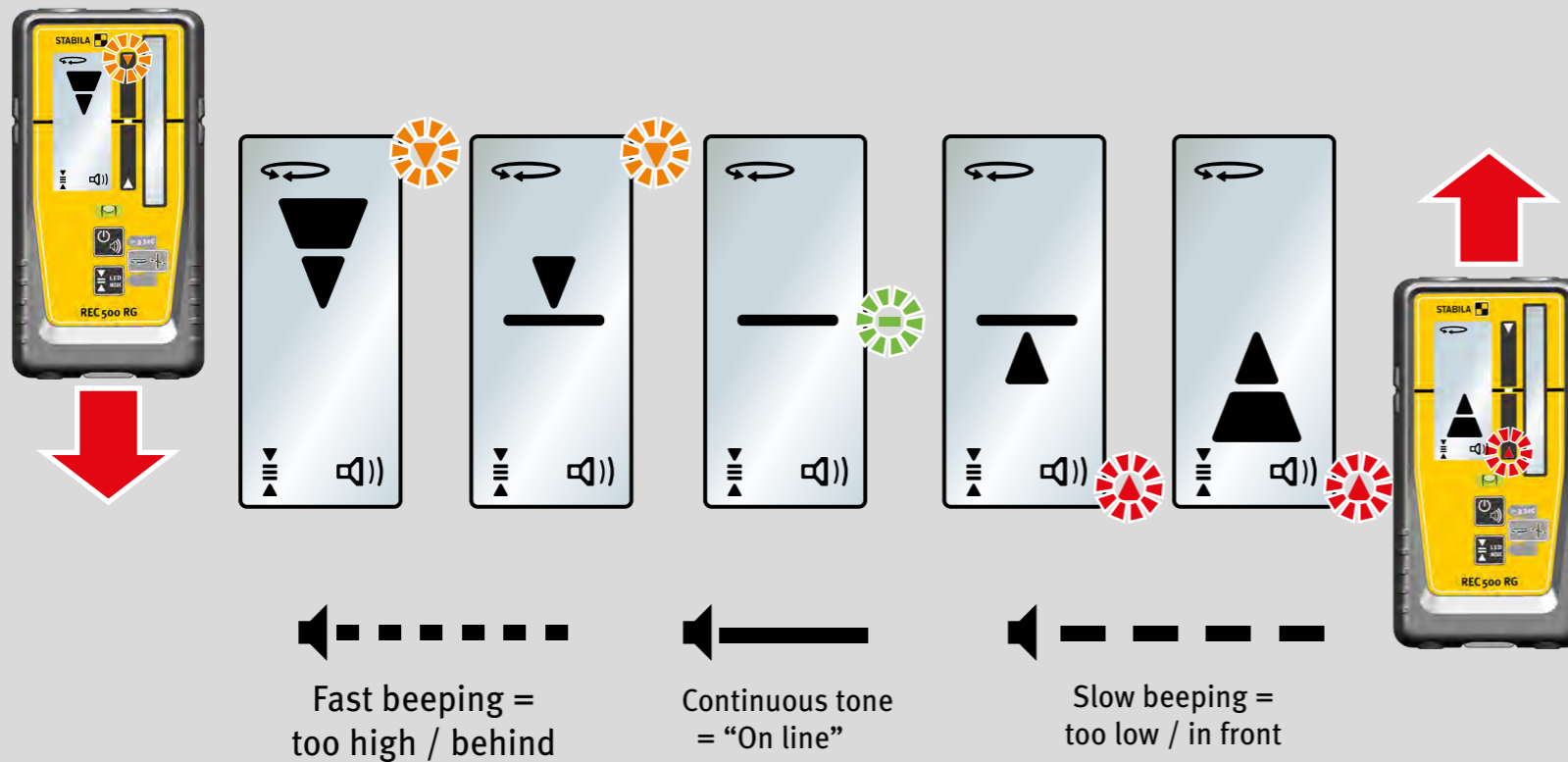

### 6.2 Acoustic guidance

The acoustic guidance is activated/deactivated using the "Acoustic guidance" button. A change in the pitch indicates that these positions have been exceeded.

A continuous tone confirms the precise point at which the "On line" position is reached.

### 6.3 Positioning and aligning the receiver

Proper handling is required to achieve a correct measurement result:

**Note:**

At close range ( $\leq 4$  m), reflections can result in incorrect measurements. Always check the plausibility of measurements taken at close range!

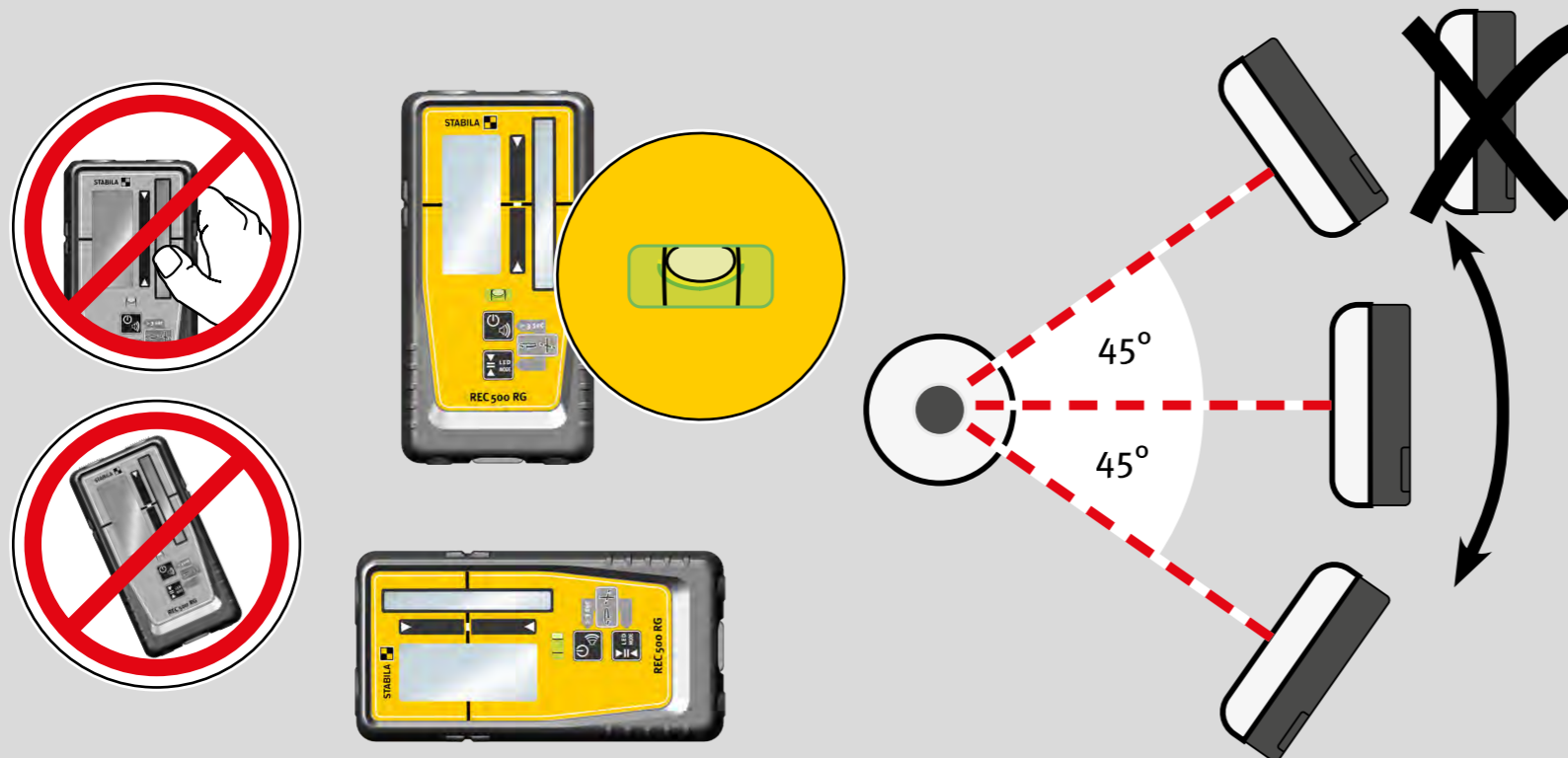



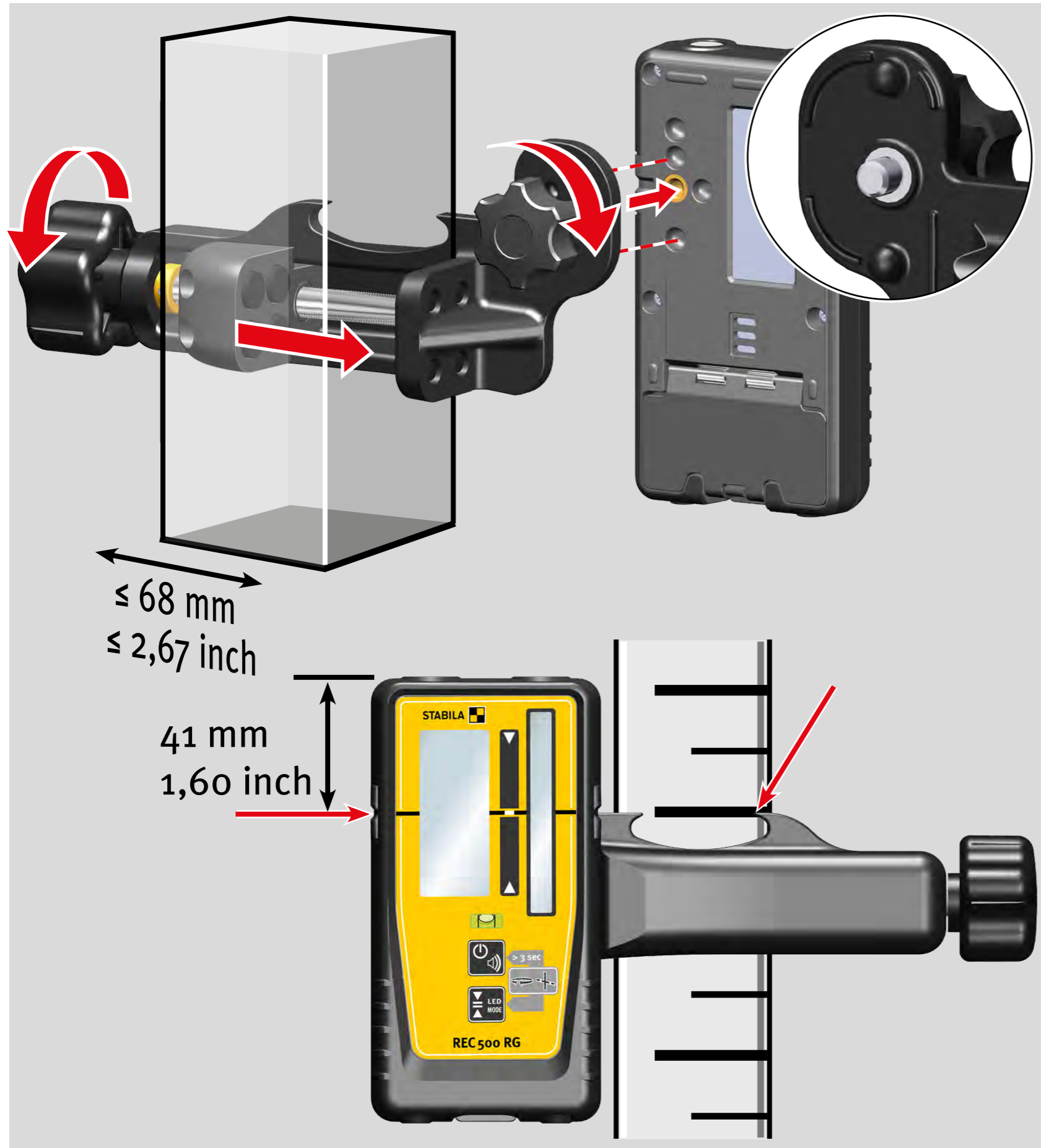

**6.4 Retaining bracket**

Mounting:  
Use the locating pins and the mounting screw to align and mount the retaining bracket on the rear of the receiver.

Reading reference

## 7 Technical data

### Accuracy:

Very fine: + 0.3 mm

Fine: + 1 mm

Rough: + 2 mm

Very rough: + 5 mm

Receiving spectrum: 450–800 nm

Acoustic signal: Loud: > 100 dBA

Soft: 75 dBA

Rotation laser speed: 300–1200 rpm

Batteries: 1 x 1.5 V alkaline, Mignon, AA, LR6

Battery life: ≥ 50 hours

Automatic switch-off: 30 minutes

Operating temperature range: -10 °C to +50 °C / 14°F to +122°F

Storage temperature range: -40 °C to +70 °C / -40°F to +158°F

Protection class: IP 67

Subject to technical modifications.

2020

**Europe**  
**Middle and South America**  
**Australia**  
**Asia**  
**Africa**



**STABILA Messgeräte**  
Gustav Ullrich GmbH

P.O. Box 13 40 / D-76851 Annweiler  
Landauer Str. 45 / D-76855 Annweiler

☎ + 49 63 46 309 - 0  
✉ info@de.stabila.com

**USA**  
**Canada**

**STABILA Inc.**

332 Industrial Drive  
South Elgin, IL 60177

☎ 800-869-7460  
✉ custservice@Stabila.com