

**STABILA®**

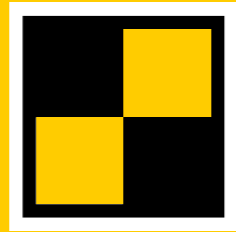

**How true pro's measure**

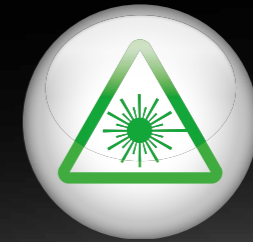

**GREEN  
BEAM**

# LAX 320 G

**Operating instructions**



**Contents**

Section	Page
• 1. Intended use	3
• 2. Safety instructions for laser units	3
• 3. Components of the unit	4
• 4. Commissioning	5
• 4.1 Inserting/removing batteries	5
• 4.2 Switching the unit on	6
• 4.3 Commissioning without the levelling function	6
• 5. Functions	7
• 5.1 Selecting laser functions	7
• 5.2 Working with the receiver	7
• 6. LED indicators	8
• 7. Application with laser base	9
• 8. Checking accuracy	10
• 8.1 Vertical check	10
• 8.2 Checking the plumb-line function	10
• 8.2 Horizontal check	11
• 9. Technical data	12

## 1. Intended use

Congratulations on the purchase of your STABILA measuring tool.

STABILA LAX 320 G is a simple-to-operate cross line and plumb-line laser for horizontal and vertical levelling. The plumb-line dots make it possible to align and create plumb lines on objects. It is self-levelling within a range of  $\pm 4^\circ$ .

The laser lines are pulsed, which makes it possible to work over greater distances using a special STABILA line receiver. Receivers must be suitable for green laser beams.

For more information refer to the operating instructions for the line receiver.

Their green colour also ensures that you can see them perfectly, even in bright lighting conditions.

 If you still have questions after reading the operating instructions, you can obtain advice over the phone at any time:

 +49 / 63 46 / 3 09 - 0

### Equipment and functions:

- Pulsed laser lines
- 1x vertical laser line
- 1x horizontal laser line
- Plumb line laser function
- Manual mode
- Mounting with rare-earth magnets
- 1/4" tripod socket
- SLB 320 laser base
- Target plate
- Fabric bag

## 2. Safety instructions for laser units

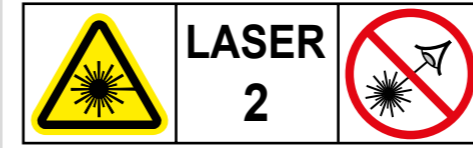

IEC 60825-1:2014

In Class 2 laser units, your eyes are usually protected from accidental, short-term exposure to the laser beam by the eyelid-closing reflex and/or the reflex reaction to turn one's head. If a laser beam hits your eye, deliberately close your eyes and move your head out of the path of the beam. Do not look into the direct or reflected beam. The STABILA laser goggles available for our laser units are not safety eyewear: their function is to improve the visibility of the laser beam.

- Do not aim the laser beam directly at people!
- Avoid dazzling other people with the unit!
- Keep the unit out of the reach of children!
- If operating or adjustment equipment that has not been specified here is used, or if the unit is not operated in the ways described here, this may result in hazardous exposure to radiation!

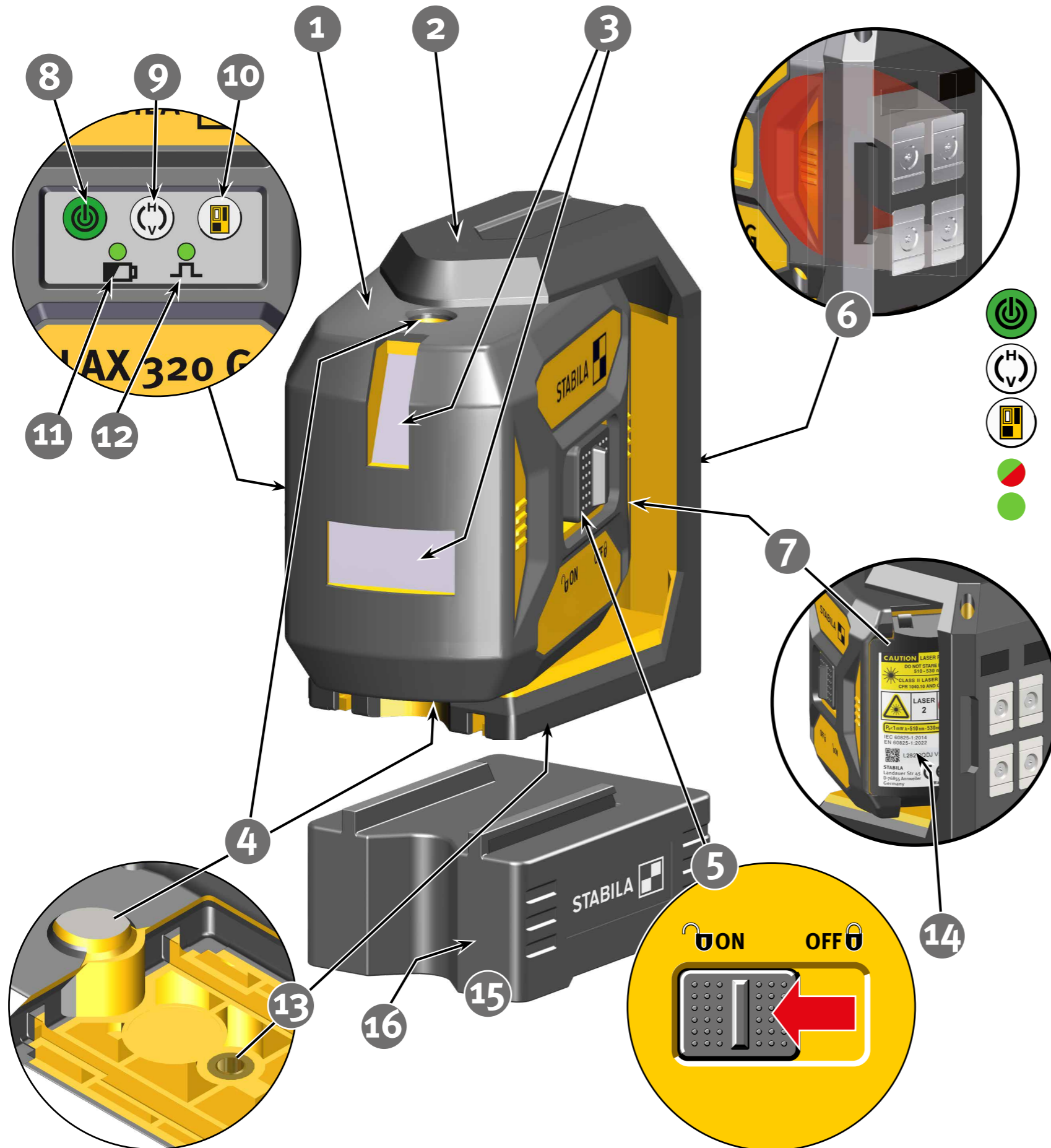

## 3. Components of the unit

1. Laser unit
2. Protective frame: with magnet and tripod socket
3. Exit window: horizontal and vertical laser line
4. Exit window: plumb-line dots upwards and downwards
5. Sliding switch: ON/OFF, mechanical lock
6. Magnet surface
7. Battery compartment lid
8. Button: Manual mode ON/OFF
9. Button: Laser lines
10. Button: Pulse mode for receiver operation
11. Green/red LED: ON/OFF, operating status
12. Green LED: Pulse mode, operating temperature
13. 1/4" tripod socket
14. Serial number
15. SLB 320 laser base
16. Contact edge: makes aligning easier with plumb-line dots



## 4. Commissioning

### 4.1 Inserting/removing batteries

Open the battery compartment lid in the direction of the arrow, remove potentially old batteries and insert new ones as indicated by the symbol in the battery compartment. Suitable rechargeable batteries can also be used.

**LED indicator:**

Red LED: low battery  
- insert new battery



Dispose of used batteries at suitable collection points – not with household waste.  
If you do not intend to use the unit for an extended period, remove the batteries!

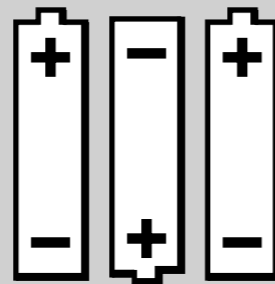

3 x 1,5V  
Alkaline  
AA, LR6, Mignon



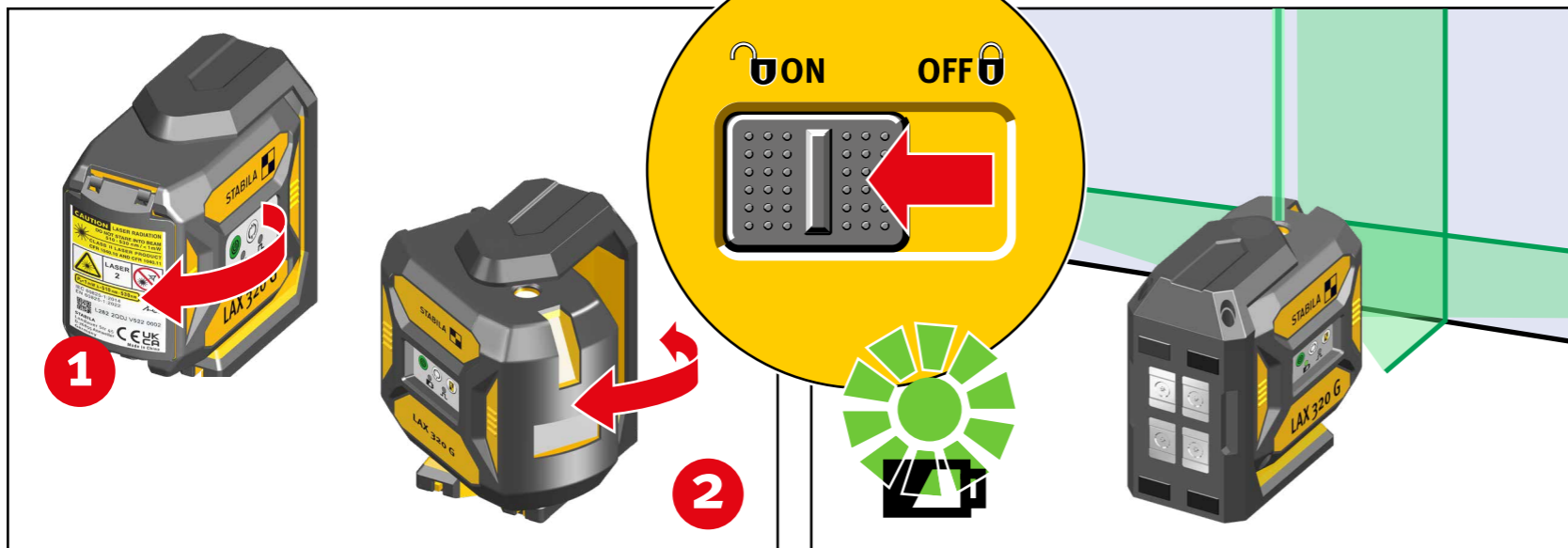

## 4.2 Switching the unit on

Move the laser unit to the working position and switch on using the sliding switch. The LAX 320 G always starts in horizontal mode and levels itself automatically. You can now select laser functions (-> 5.1.). The green LED indicates that the unit is switched on.

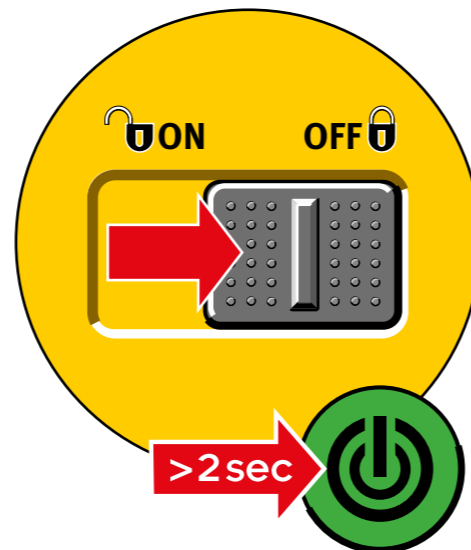
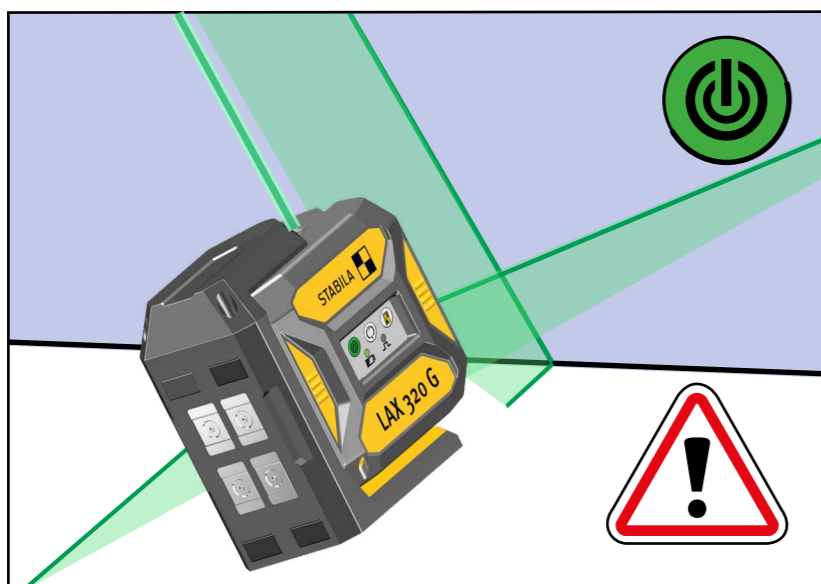
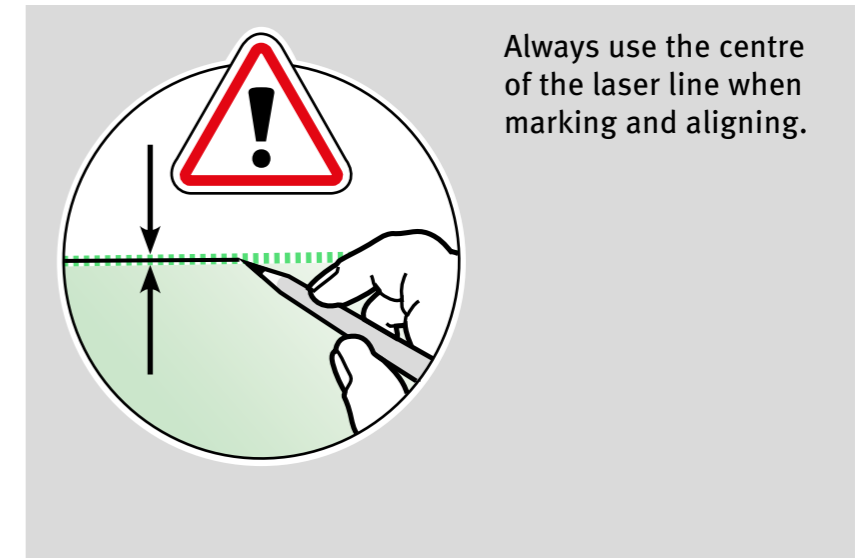
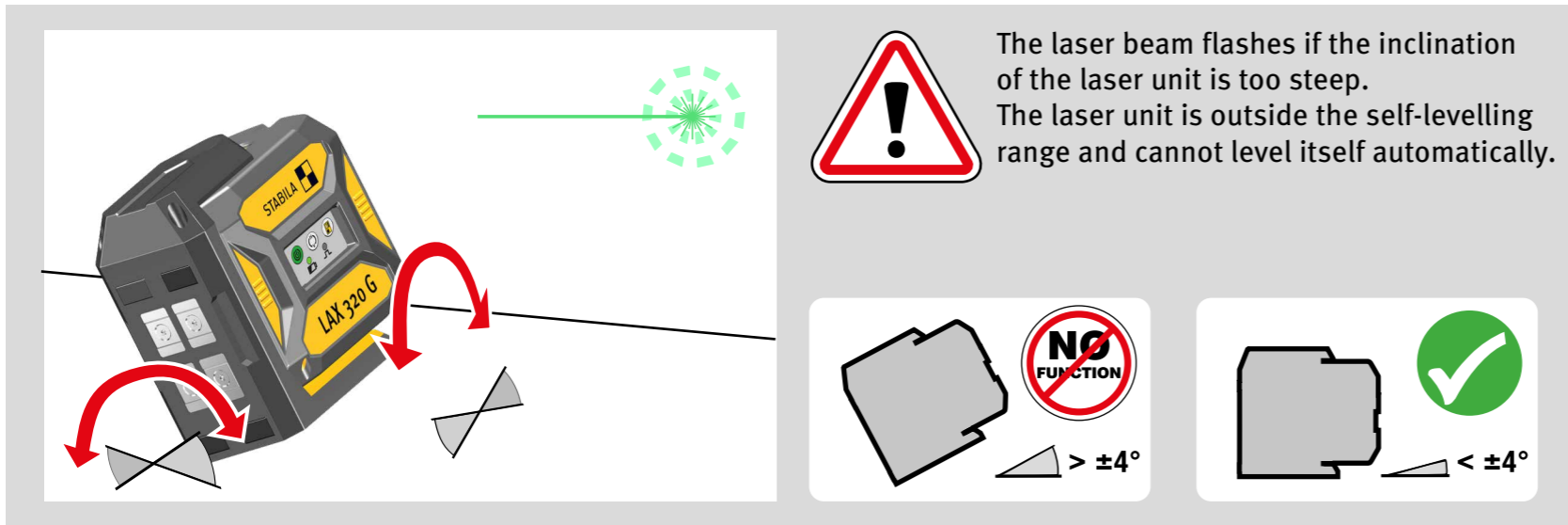

## 4.3 Commissioning without the levelling function

Marking function mode can only be switched on with the "Manual mode" switch. To do this, press and hold it for more than 2 seconds. The laser beam flashes 2x every 5 seconds. The LAX 320 G is not in self-levelling mode and can only be used in this mode for marking and alignment!

## 5. Functions

### 5.1 Selecting laser functions

Once the unit has been switched on, use the "Laser lines" button to switch between the various laser functions.

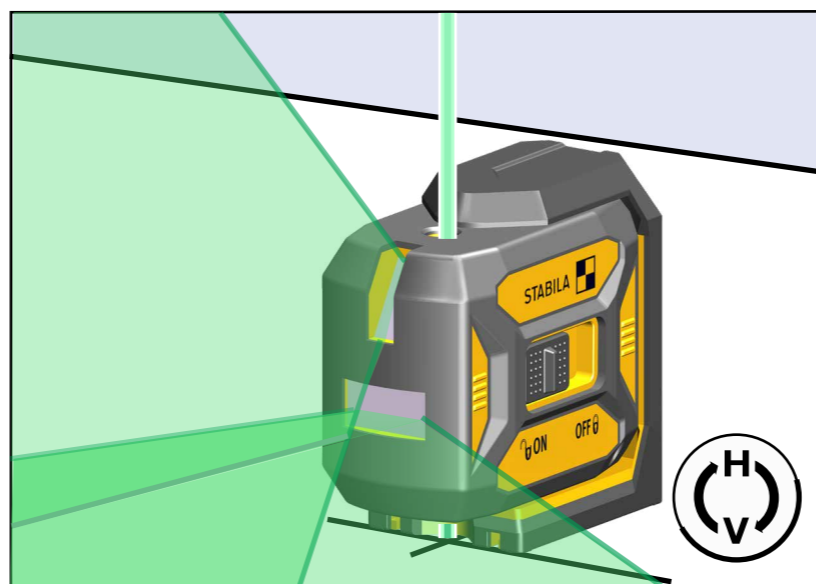
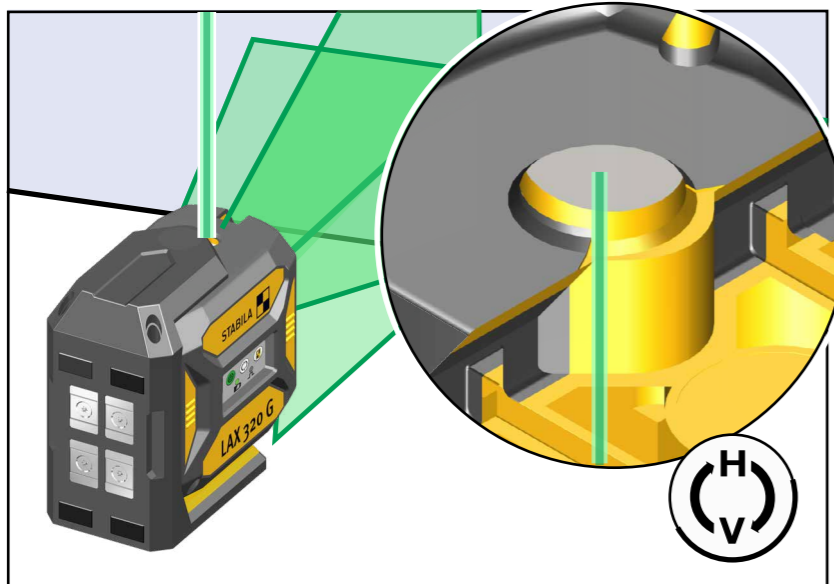
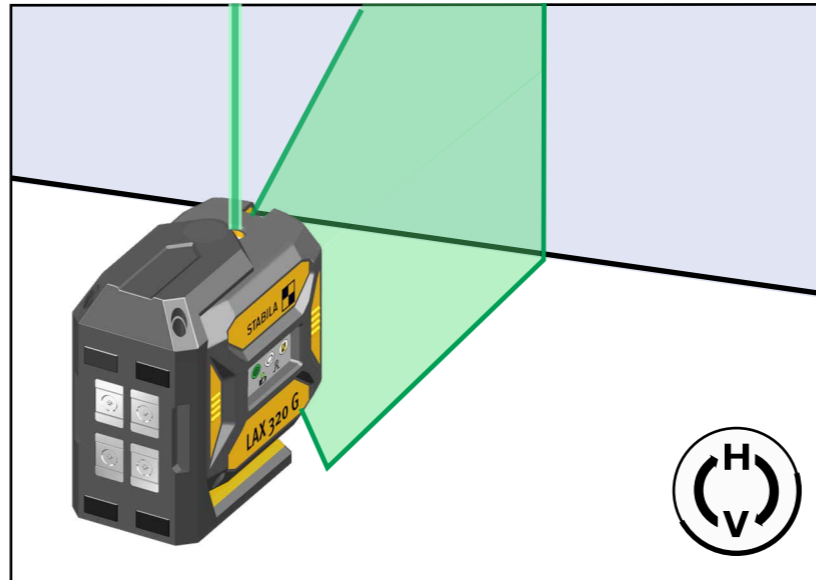
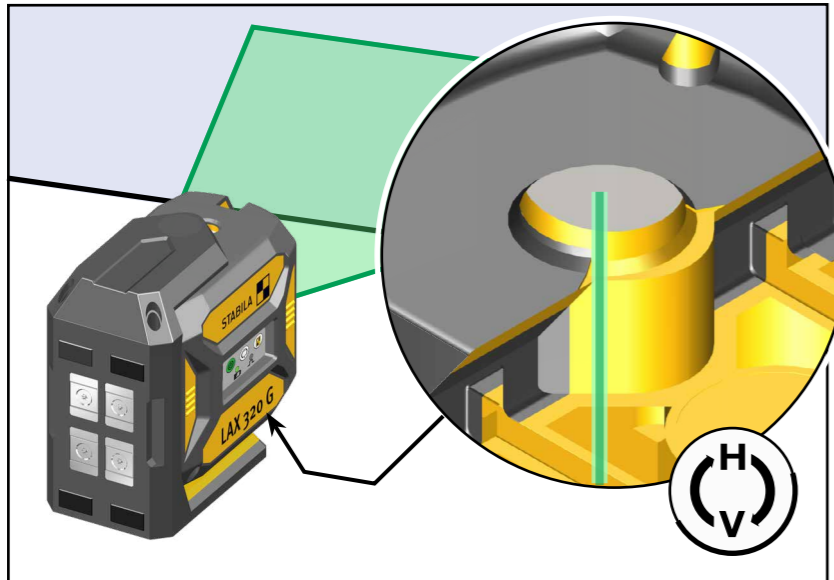

### Plumb-line function

Transfers a determined point from the floor to the ceiling.

### 5.2 Working with the receiver

Pulse mode must be activated for work completed over larger distances or using a suitable receiver.

Note:  
The receiver must be suitable for pulsed and green laser lines.

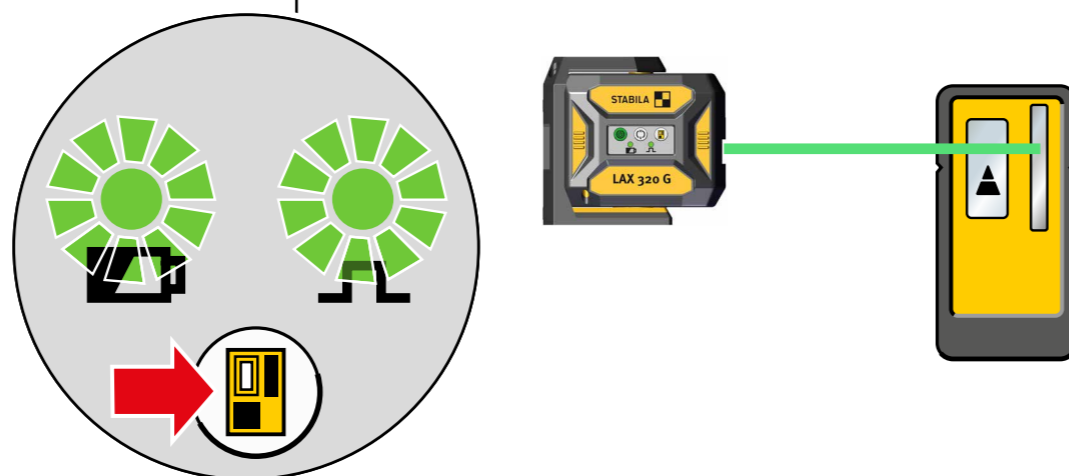

## 6. LED indicators

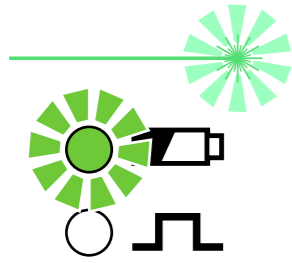

Operation with levelling function

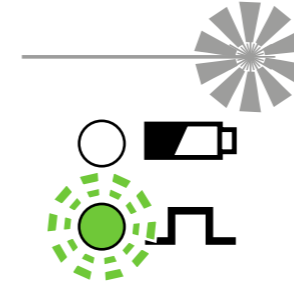

Operation activated  
Unit temperature 60°C / 140°F  
Ensure the unit is in the operating temperature range

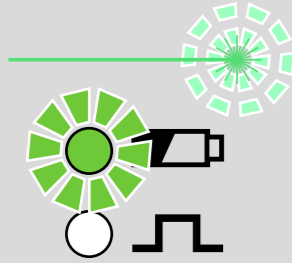

Operation without levelling function



LED/laser beam lights up constantly

LED/laser beam flashes

LED flashes and changes colour

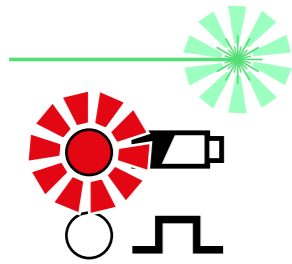

Operation with levelling function  
Battery capacity low

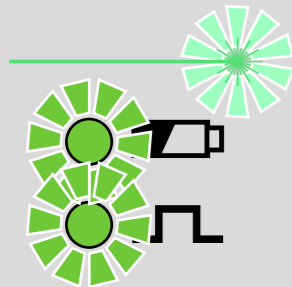

Operation with levelling function  
Laser in pulse mode

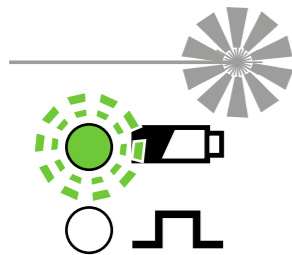

Operation activated  
Unit temperature < -20°C / -4°F  
Ensure the unit is in the operating temperature range  
Check accuracy

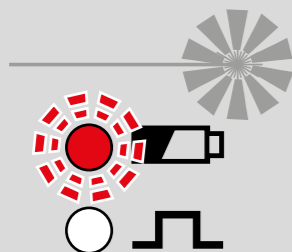

Operation activated  
Unit temperature > 70°C / 158°F  
Ensure the unit is in the operating temperature range  
Check accuracy

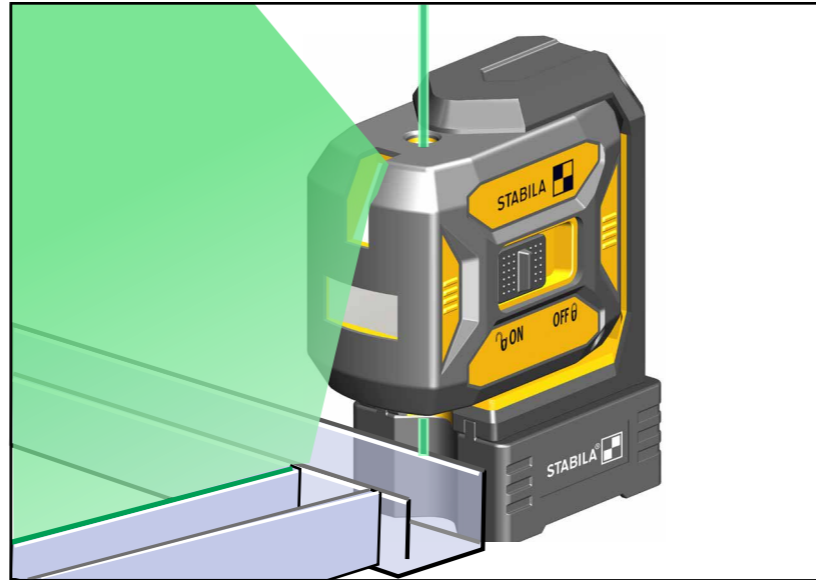

## 7. Application with laser base

For exact positioning, use the SLB 320 laser base to set the LAX 320 G up on interior construction profiles. Consequently, the plumb-line laser is accurately aligned with the component edge.

Slide the laser base into the protective frame up to the stop using its profile rails.

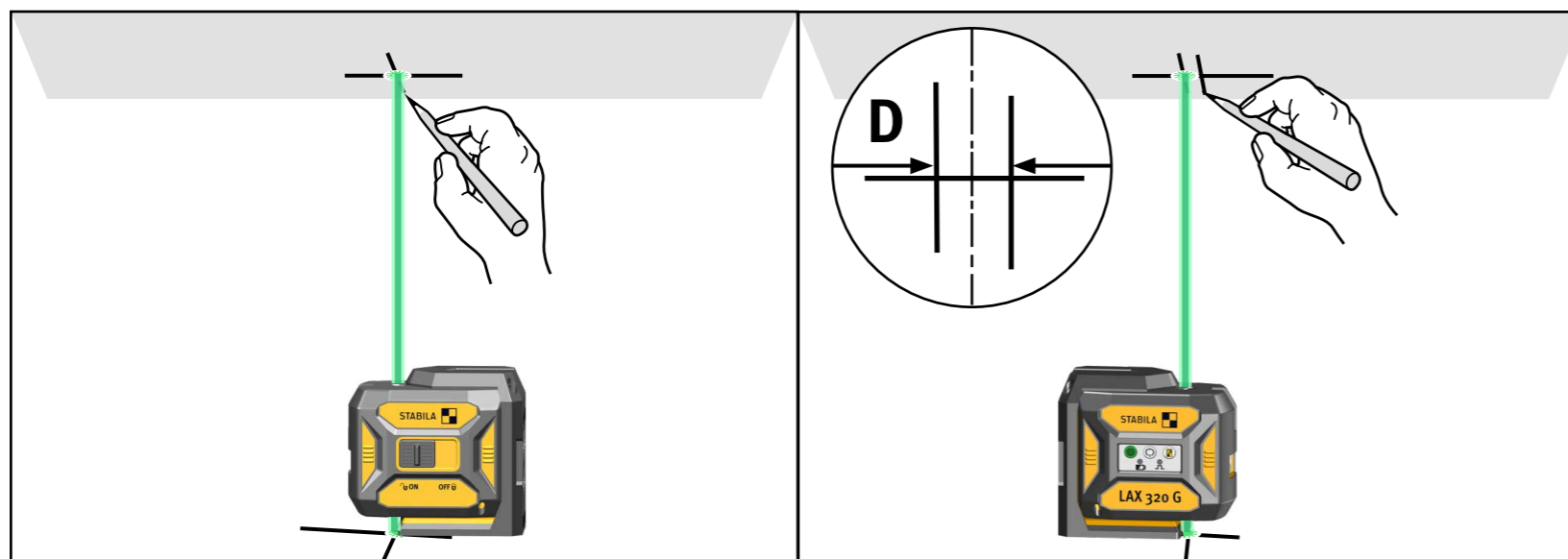
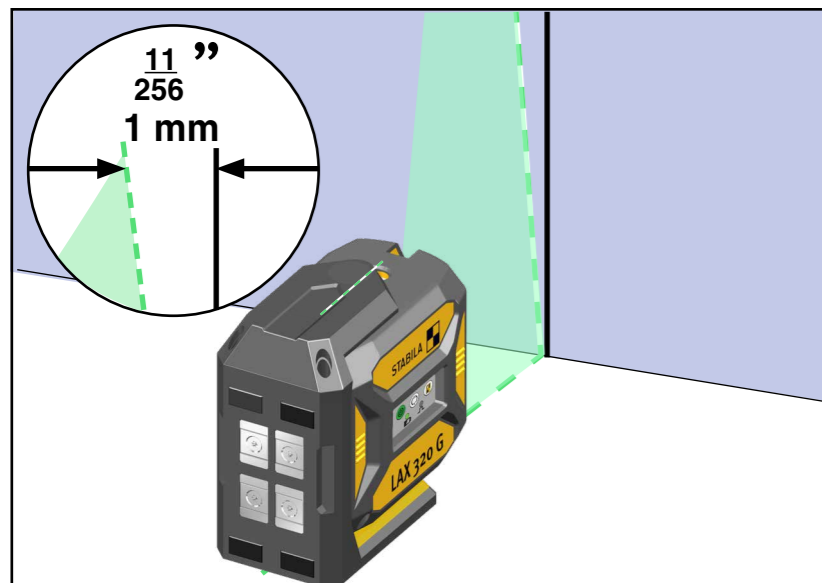
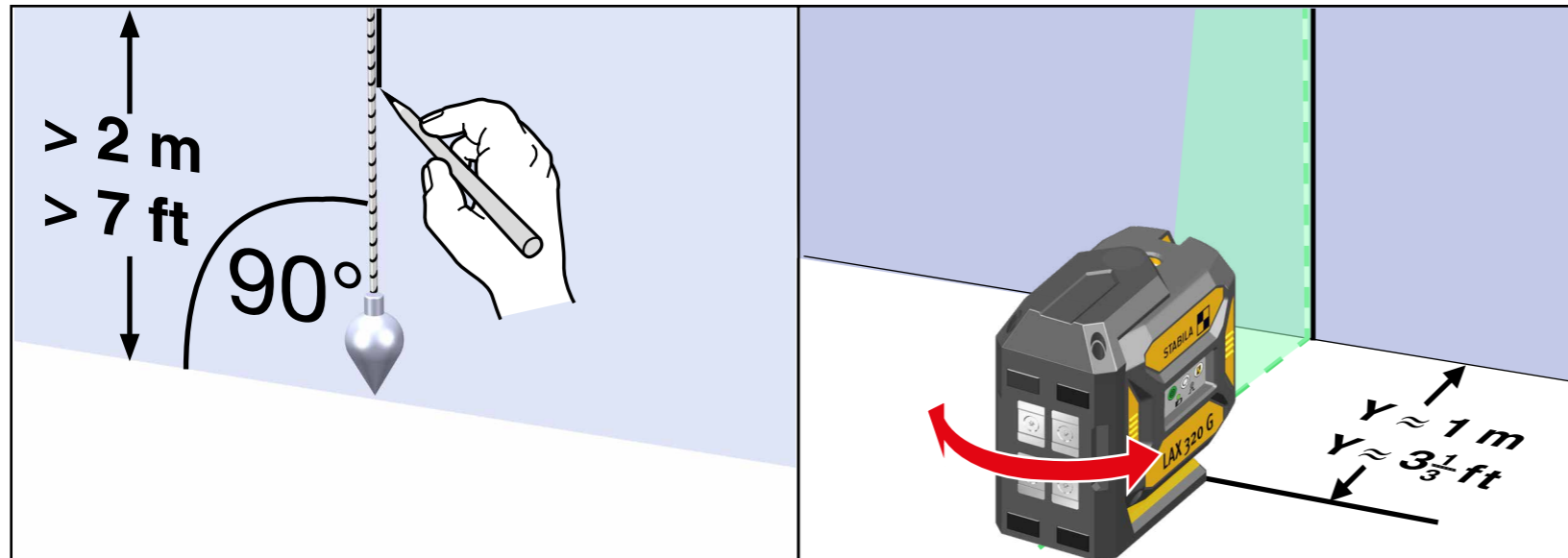

## 8. Checking accuracy

The LAX 320 G is designed for use on building sites and is perfectly adjusted before leaving our premises. As with all precision instruments, check the calibration accuracy of the unit on a regular basis. Always check the unit before you start work, especially if it has been exposed to heavy vibrations.

**Vertical check**  
**Horizontal check**

### 8.1 Vertical check

#### Checking vertical laser lines

1. Create a reference line, e.g. with a plumb line.
2. Set up and align the LAX 320 G at a distance of Y in front of this reference line.
3. Compare the laser line with the reference line.
4. At a distance of 2 m / 7', the laser line must not deviate from the reference line by more than 1 mm / 11/256"

### 8.2 Checking the plumb-line function

1. Align the LAX 320 G precisely with one floor marking using the plumb-line dot.
2. Draw plumb-line dot 1 upwards on the room ceiling.
3. Turn the LAX 320 G by 180° and re-align it with the floor marking using the plumb-line dot.
4. Draw plumb-line dot 2 upwards on the room ceiling.
5. The difference measured between the markings is twice the actual discrepancy. With a ceiling height of 5 m (16'5"), the difference must be no more than 3 mm (1/8").

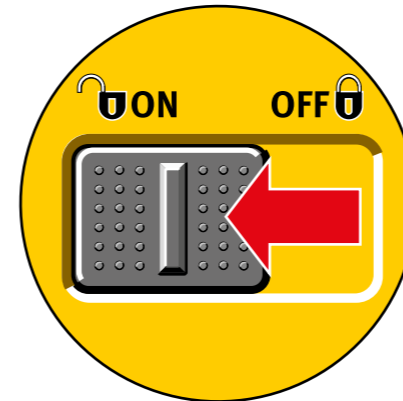
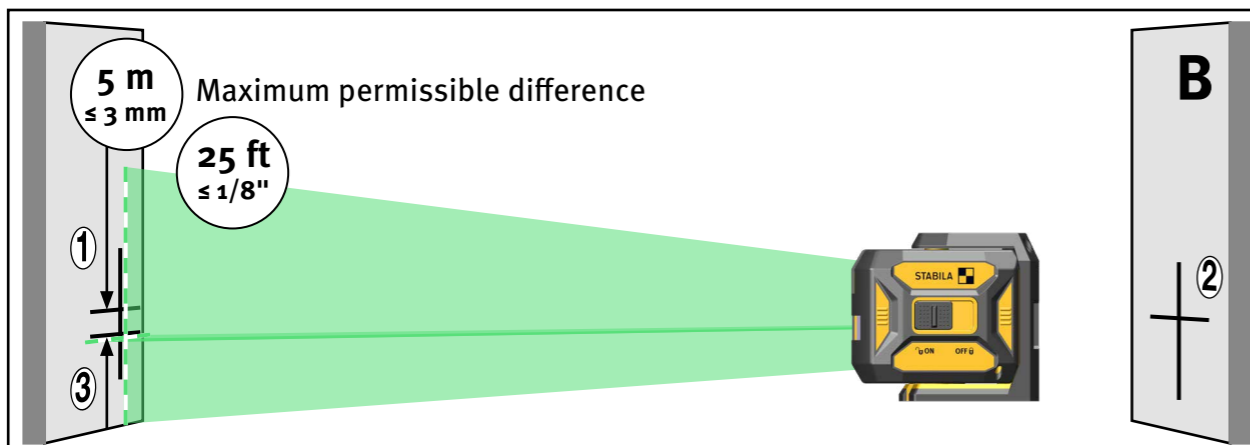
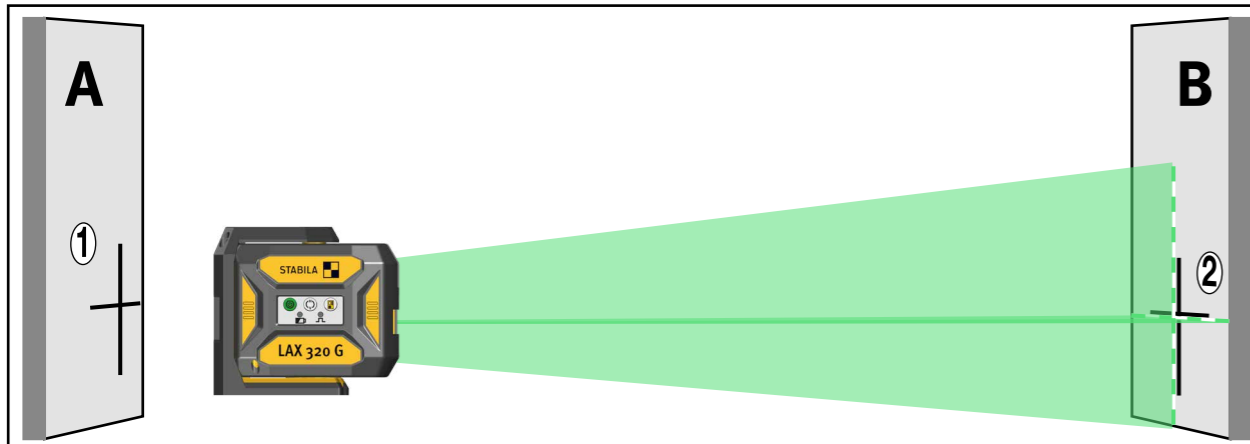
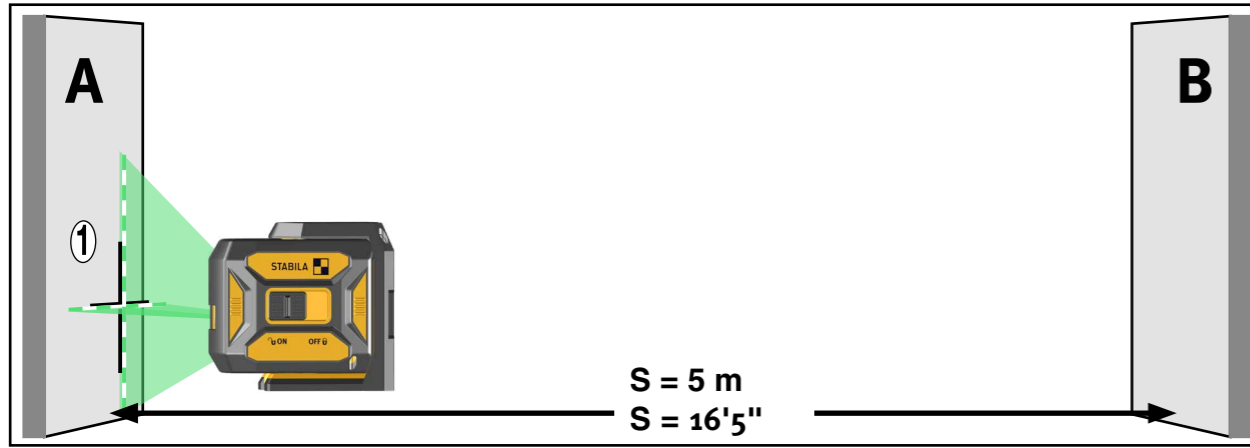

## 8.2 Horizontal check

### Checking the line level of the horizontal laser line

2 parallel walls at least 5 m / 16'5" apart (distance S) are required for the horizontal check.

1. Position the LAX 320 G as closely as possible to wall A on a horizontal surface.
2. Use an exit window for a vertical laser line to align the LAX 320 G with wall A.
3. Switch on the laser unit.
4. Once automatic levelling has ended, mark the cross projected onto wall A. Point 1.
5. Turn the LAX 320 G around 180° and align with wall B using the same vertical laser line exit window. Do not adjust the height.
6. Once automatic levelling has ended, mark the cross projected onto wall B. Point 2.
7. Now reposition the laser unit so that it is directly in front of wall B. Align the LAX 320 G with wall B using the same exit window for a vertical laser line.
8. Move the laser line cross by turning and adjusting the height until it precisely coincides with point 2.
9. Turn the LAX 320 G around 180° and align with wall A using the same vertical laser line exit window. Do not adjust the height.
10. Move the laser line cross by turning the casing until it precisely coincides with the marking line of point 1.
11. Once automatic levelling has ended, mark the cross projected onto wall A. Point 3.
12. Measure the vertical distance between points 1 and 3.

Distance S to the wall	Maximum permissible distance:
5 m	3.0 mm
10 m	6.0 mm
15 m	9.0 mm
16'5"	1/8"
32'10"	1/4"
49'3"	3/8"

## 9. Technical data

Laser type:	Green diode laser, wavelength 510–530 nm
Power output:	< 1 mW, laser class 2, in accordance with IEC 60825-1:2014 EN60825-1:2014/A11:2021
Self-levelling range:	approx. $\pm 4^\circ$
Levelling accuracy*:	
Laser line:	$\pm 0.3$ mm/m centre of laser line
Batteries:	3 x 1.5 V alkaline, Mignon size, AA, LR6
Battery life:	$\leq 15$ h
Operating temperature range:	-10°C to +50°C / 14°F to 122°F
Storage temperature range:	-25°C to +70 °C / -13°F to 158°F

Subject to technical modifications.

\* When operated within the specified operating temperature range

2025

**STABILA Messgeräte**  
Gustav Ullrich GmbH  
Landauer Str. 45  
76855 Annweiler  
Germany