



# Laser LAR-250

**en** Operating instructions



A

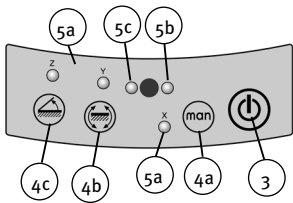

STABILA  
Laser LAR 250

Laser-Classe  
Laserklasse = 635 nm  
EN 60825-1:2014  
EN 60825-2:2014

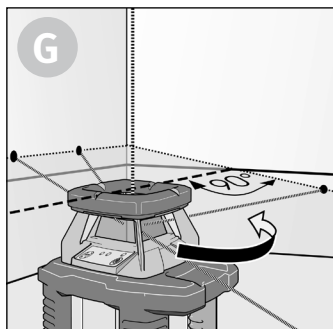
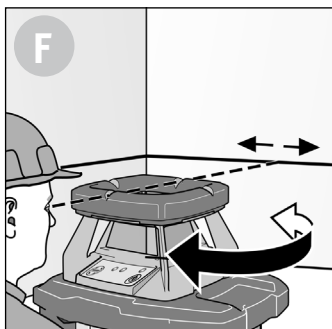
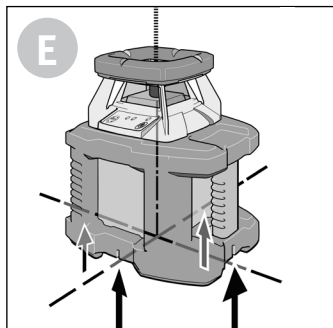
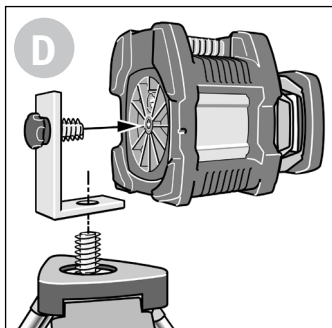
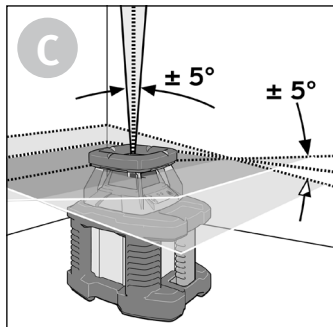
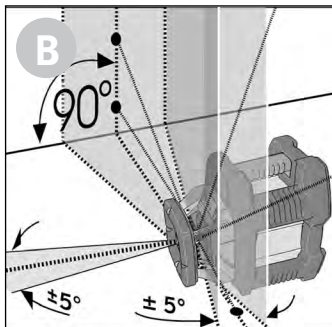

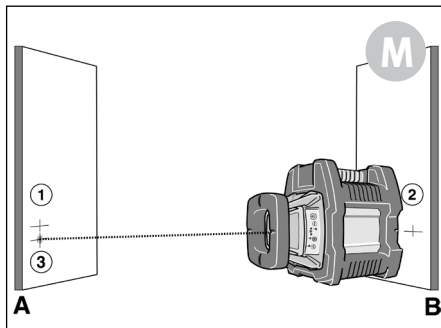
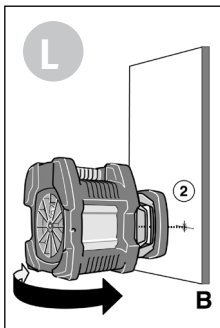
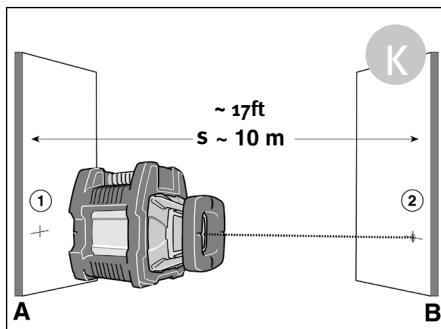
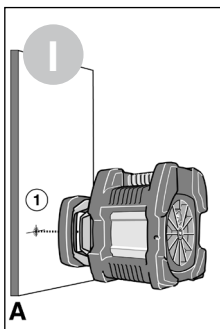
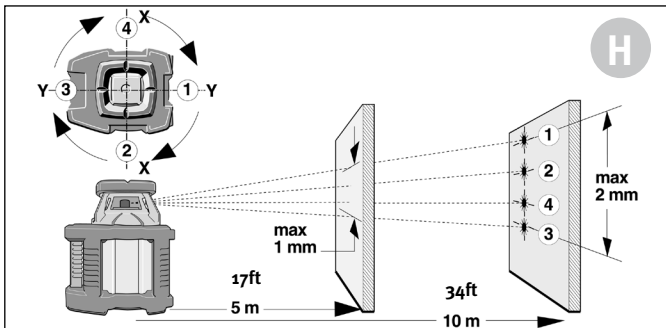

## Operating instructions

The STABILA LAR-250 rotation laser is an easy to operate rotation laser for horizontal and vertical levelling and plumb lines. The LAR-250 has a sealed casing (IP 65). It is self-levelling in a range of  $\pm 5^\circ$ . The laser beam can be received at distances of up to 175 m (570 ft) with the use of a receiver, even when it is no longer visible to the naked eye.

We have endeavoured to explain the unit's handling and functioning in as clear and comprehensible manner as possible. If, however, you still have any unanswered questions, we should be pleased to provide advice over the telephone at any time on the following telephone number:

+49 / 63 46 / 3 09-0

A

### Main components

Splitter pentaprism SP:

- (1) SP1: vertical beam emission aperture
- (2) SP2: rotation beam emission aperture
- (3) ON/OFF switch
- (4a) Automatic levelling On/Off selector switch
- (4b) Permanent adjustment On/Off selector switch
- (4c) Selector switch for bending the laser beam in one axis
- (5a) LEDs for displaying:
- (5b) LED red : battery voltage and overheat
- (5c) LED green : Operating mode ON or READY / OK
- (6) Shock protection
- (7) Battery compartment cover
- (8) 5/8" threaded connector for tripod
- (9) Targeting marks
- (10) Feet for vertical levelling
- (11) 4 markings to create a plumb-line laser function
- (12) Housing: hoseproofed sealings and dustprotected acc. to standard IP65  
Do not submerge the laser !



E

## Remote control: Adjusting and aligning the laser beam



(16) -> Selector switch: Rotation function - Scan function

Rotation function:



(19) -> Reduce rotation speed



(20) -> Increase rotation speed

Rotation speed = 0



(17) -> The laser dot moves to the left



(18) -> The laser dot moves to the right

Scan function:



(17) -> The scanning line moves to the left



(18) -> The scanning line moves to the right

Scan funktion:



(20) -> The scanning line is longer



(19) -> The scanning line is shorter

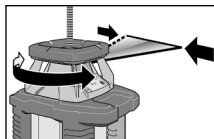
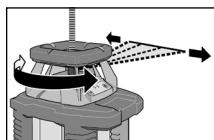
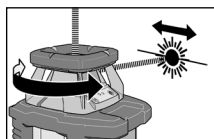
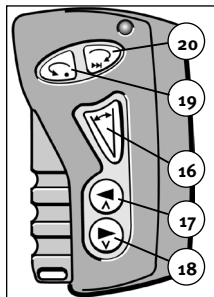

When working with the remote control, this must be oriented to the laser's operating field.

0

## Recycling programme for our EU customers:

In accordance with the WEEE regulations, STABILA provides a disposal programme for electronic products at the end of their service life.

For more details, please contact: +49 / 6346 / 309-0



## Main applications:

### Levelling

Set the unit on a firm base or a tripod.

Tip: It is useful to set up the rotation laser centrally to the subsequent measurement points.



Pressing the button (3), switches the rotation laser ON and it starts to level itself automatically. Once levelling is complete, the laser begins to rotate. Depending on the brightness of the ambient light, you can either use the laser beam, if easily visible, for marking directly (always ensure that you mark the centre of the laser beam) or the beam can be received via the receiver.

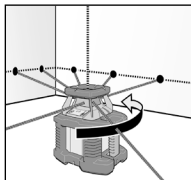

The rotation speed (buttons 19, 20) and the scan function (button 16) can be set by remote control. Buttons (17) and (18) are used to move the scanning line and/or the laser dot to the right or to the left.



Please note that the centre of laser dot is marked!

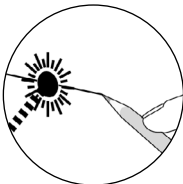

## Operating modes:

### Commissioning

#### - Automatic mode with height of tool alert function (Y LED)

For safety reasons, the rotation laser always switches itself off all when it is switched on in this operating mode!

The unit can be switched on by briefly tapping button (3). Automatic levelling starts immediately. The green LED (5c) lights up and the Y LED flashes. The split-pentaprism begins to rotate and the laser beam comes on. After automatic levelling, you have approximately 30 seconds in which to set the laser unit in the desired position, e.g. to adjust its height, set it on a tripod, etc.

During this time, minor discrepancies from the horizontal are ironed out. Then the laser unit switches to monitored Automatic mode and the Y LED goes out.





## Height of tool alert function

Minor tremors or vibrations are automatically compensated for only up to a set threshold. If these disruptive influences are greater than this, the height of tool alert function engages and rotation stops. The laser beam switches off and the Y LED flashes. You must switch the laser unit off using button (3) and then switch it on again.

Disruptive influences that can lead to adjustment of the precise alignment and the laser beam's setting do not therefore go unnoticed. When there are disruptive influences present, the height of tool alert function requires the laser to be checked and/or reset to the desired position.



## Automatic mode with subsequent readjustment (Y LED)

In many operating conditions (e.g. on strongly vibrating surfaces), it is useful for the rotation laser to level itself constantly to eliminate any discrepancies that may arise. After switching it on with button (3), the unit can be switched to this mode by pressing button (4b). The red LED indicates that this mode is active. Minor discrepancies from the horizontal (from minor tremors) are compensated for. If these disruptive influences are too great, rotation stops, the laser beam switches off and the laser unit levels itself again automatically. Once re-levelling is complete, the splitter Pentaprism starts to rotate again.

C

D



3



4b

## Manual mode without levelling (X- LED)

To be able to mark inclinations over  $5^\circ$  in one plane or inclinations in two planes, once the unit is switched on (button 3), automatic mode can be switched on by pressing button (4a). The unit can now be tilted in any direction (e.g. by moving the tripod). This mode is indicated by the red LED (9b).



3



4a

## Manually tilting one axis by $\pm 5^\circ$ - with transverse axis levelling (Z-LED)

This mode enables you, for instance, to lay out gradients in a particular direction.

F

G

Manually align the unit precisely at right angles to the direction of the desired inclined plane using the targeting marks (9). Ideally: align it along a reference line, e.g. parallel to a wall.



After switching on (via button 3), press button (4c) until the Z LED lights.

The unit is now in height of tool alert function mode.



Buttons (17) and (18) on the remote control can now be used to incline this laser plane at right angles to the line from the targeting marks. The inclined plane is automatically levelled horizontally in this line's direction.



(17) -> The laser plane tilts



(18) -> The laser plane tilts in the opposite direction

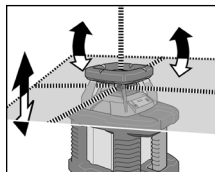

## B Marking out vertical areas (vertical levelling)

Set the rotation laser on its side feet for vertical levelling (10). Align the unit manually so that the direction of the vertical laser plane described by the lens is approximately parallel or at right angles to a reference line (e.g. a wall or a corner).



Press button (3) briefly to switch the unit on. It is now in Height of Tool Alert function mode.



You can use the remote control to set the rotation speed (17, 18) or to switch over between point and line function (16). The vertical laser plane described by the rotating deflected laser beam can only be adjusted in Point mode, by  $\pm 5^\circ$ , using buttons (17) and (18). In this way, the laser plane can be aligned precisely parallel or at right angles to the reference line.



16

## E Use as a Plumb-line Laser

The laser can be aligned precisely on a marked cross using the 4 markings (15) on the base to transfer a plumbline from the floor marking to the ceiling. The point where the cross intersects corresponds to the SP1 vertical laser emitter.

A correct result can only be obtained in Automatic mode with the unit set on a level surface !

## Vertical levelling

Adjusting only in point mode  
(only using the Rotation and not the Scan function)



(17) -> The laser plane moves to the left



(18) -> The laser plane moves to the right

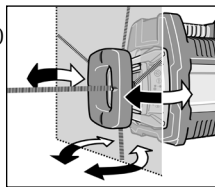

B

## 2 basic methods of vertical levelling

### Generating parallel planes:

Swivelling until  $S_1 = S_2$

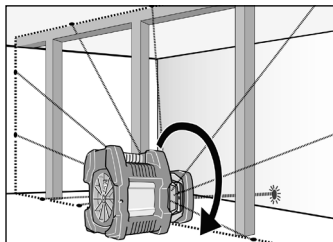
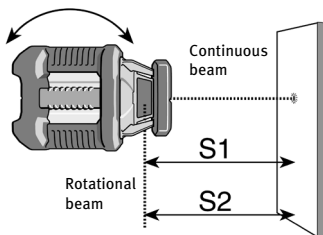

Creating vertical reference areas, e.g. measuring dividing walls.

### At right angles to the wall:

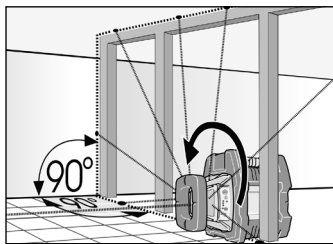
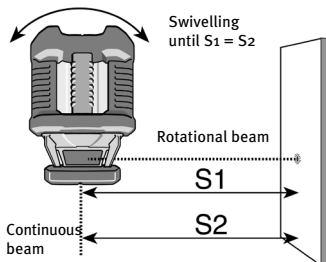

Measuring tiles, panels, parquet (floors, ceilings, walls), measuring right angles simply by swivelling the unit.

## Checking the calibration

The LAR-250 rotation laser has been designed for building site use and leaves our factory perfectly calibrated. As with any precision instrument, however, its calibration must be regularly checked. The unit should be checked before starting any new tasks, particularly when the unit has been exposed to strong vibrations. After an impact, the unit should be checked throughout its whole self-levelling range.

### Horizontal checking

 Please keep as closely as possible to the alignment shown in (H) because this simplifies any re-adjustment that may be required



1. Set up the rotation laser on a smooth, level surface or on a tripod 5 or 10m (25 ft or 50ft) from a wall with the front facing the wall.

3



2. Switch the unit on (button 3) and wait for it to level automatically. The laser dot is turned in the direction of the wall (button 17, 18). It is also possible to work with a receiver.



18

3. Mark the position of the visible laser dot on the wall - Measurement 1 (Point 1). Because the diameter of the beam depends on the distance, you must always only use the centre of the dot!

H1



17

4. Turn the complete unit 90° without altering the height of the laser (i.e. the tripod must not be altered). Let the unit level automatically again. Then turn SP2 in the direction of the wall in the area of measurement point 1.



18

5. Mark the position of the visible laser dot on the wall (Point 2).

H2

H3

6. Repeat steps 4 and 5 to obtain Points 3 and 4.

H4

7. If the difference between the 4 control points is less than 1mm at 5m (1/8" at 17ft) distance and 2 mm at 10m (1/4" at 34ft) distance the permissible tolerance of  $\pm 0.1$  mm/m ( $\pm 1/8$ " over 100ft) is being maintained. Points 1 and 3 on the unit's y-axis and points 2 and 4 on the unit's x-axis now correspond.

## Adjustment - Horizontal

If the readings are determined as being outside the tolerance limits during the horizontal check, the laser can be adjusted as follows. The decisive factor is the distance between the opposing measurement points, i.e. points 1 + 3 and 2 + 4. Points 1 and 3 on the unit's y-axis and points 2 and 4 on the unit's x-axis now correspond. For example, if the distance between points 2 + 4 is outside the tolerance limit of 0.1 mm/m, the laser must be adjusted along this axis!

Full batteries must be used when using the adjustment function!

Set the laser with this axis (x-axis) facing the wall. Switch the unit off. To go to Adjustment mode, hold down button (4a) first. Additionally press button (3). As soon as the Y LED illuminates, release button (4a). The X LED now flashes rapidly. Switch on the "Rotation" function with the remote control (button 16). The height is checked with the receiver.

The laser is correctly adjusted when the laser dot is precisely centred between Points 2 and 4. Adjust the dot's height using buttons (17) and (18) on the remote control until it is precisely between Points 2 and 4.

Now turn the laser 90° until the y-axis is facing the wall. Now turn SP2 prism until the laser dot is facing the markings.

If the centre of the laser dot does not correspond to the centre of the dot when the x-axis was adjusted, switch to Adjustment mode using button (20) on the remote control.

The Y LED now flashes rapidly. Adjust the height of the laser dot using buttons (17) and (18) until it is precisely at the height of the centre mark for the x-axis.



3



4a



17



18



20

## Saving the adjustment

The laser is now adjusted again. Pressing button (19) on the remote control saves the settings. If you do not wish to save the setting, exit Adjustment mode without saving by pressing the button (3) on the laser. The old setting is then kept unchanged.



19



3

## Vertical checking (The unit is tilted 90° to the side foot).

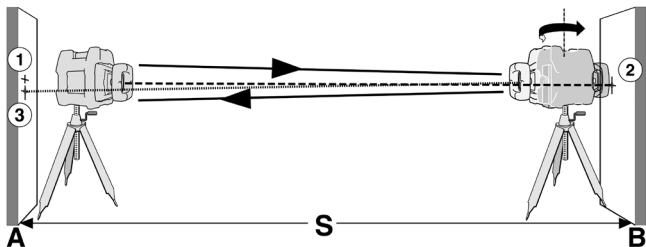

Two parallel wall surfaces at least 10m ( or 50 ft) apart are required for the vertical check.

- I 1. For vertical levelling, the rotation laser is set directly in front of wall A either on its side feet or mounted on a tripod.
- 3 2. Switch the unit on and let it level automatically - Button (3)
- 3 3. Align the laser beam against wall A.
- I 4. Mark the position of the visible laser dot on wall A (Point 1).
- K 5. Turn the complete unit 180° without altering the height of the laser. The tripod must not be altered.
6. Let the unit level itself again or switch it on again.
7. Mark the centre of the laser dot visible on wall B (Point 2).
- L 8. Now move the unit directly in front of wall B
9. Direct the laser beam on wall B.
10. Let the unit level itself again or switch it on again.
- I 11. Set the unit's height (ideally on a cranking tripod) so that the laser dot's height matches that of Point 2. Wait for the laser to level again.
- L 12. Turn the laser unit 180° without altering the laser's height. The tripod must not be altered.
13. Let the unit level itself again or switch it on again.
- M 14. Mark the centre of the laser dot visible on wall A (Point 3).
15. When the unit is 10m away from walls A and B , the distance between Points 1 and 3 should not be more than 2mm (50ft / 1/8").

$$0,1 \frac{\text{mm}}{\text{m}} \geq \frac{\overline{P_1 P_3}}{25}$$

$$1/8'' \text{ over } 100\text{ft} \text{ or } 1/816 \frac{\text{inch}}{\text{ft}}$$

## Adjustment - Vertical

If a tolerance has been exceeded when performing the vertical check, the laser can be re-adjusted as follows. Switch the laser off. To go to Adjustment mode, hold down button (4a) first. Additionally press button (3). as soon as the y LED illuminates, release button (4a).

The Z LED now flashes rapidly.

The laser can now be adjusted in the Z-axis.

The laser is correctly adjusted when the laser dot is precisely centred between Points 1 and 3 for the vertical check. Adjust the dot's height using buttons (17) and (18) on the remote control until it is precisely between Points 1 and 3.

Full batteries must be used when using the adjustment function!



3



4a



17



18

## Saving the adjustment

The laser is now adjusted again. Pressing button (14) on the remote control saves the settings. If you do not wish to save the setting, exit Adjustment mode without saving by pressing the button (3) on the laser. The old setting is then kept unchanged.



19



3

## Replacing the batteries

### Rotation laser

Unfasten the catch on the battery compartment cover: remove the cover and the batteries. Insert new batteries following the instructions in the battery compartment. Only use 1.5V mono cells (size D)!

Suitable batteries can also be used.

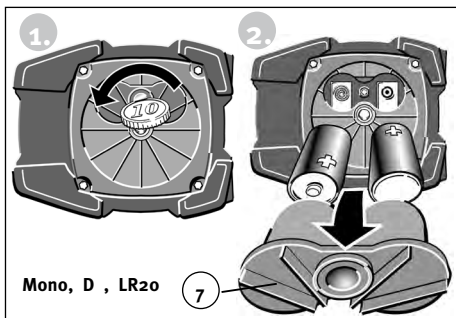

Mono, D , LR20

7

### Remote control

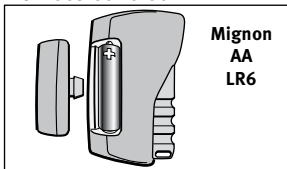

Mignon  
AA  
LR6



### Tip:

Remove the batteries if the unit will not be used for a long period !

## Operating status display and error messages via the LEDs

The red LEDs (5a) next to the corresponding buttons show the operating mode selected.

|  |  |
|--|--|
| Illuminated green LED                                      | -> laser in operation  |
| Illuminated green LED + laser beam flashing                | -> The laser levels itself automatically   |
| Flashing green LED + laser beam flashing                   | -> The unit is inclined too much<br>+ is outside the self-levelling range<br>+ the laser cannot level itself automatically   |
| Illuminated red LED  | -> laser in operation<br>-> battery voltage very low<br>-> battery replacement required imminently   |
| Illuminated red LED + laser beam flashing                  | -> The laser levels itself automatically<br>-> Battery voltage very low<br>-> Battery replacement required imminently  |
| Flashing red LED + laser beam flashing                     | -> Battery voltage very low<br>-> The unit is inclined too much<br>+ is outside the self-levelling range<br>+ the laser cannot level itself automatically  |
| The red + green LEDs flash + the laser beam cannot be seen | -> The temperature in the unit is over 50°C / or 122°F<br>-> The laser diodes have been switched off to protect against overheating<br>-> Place the unit in the shade to be able to continue working.<br>-> The laser is not working |

### NB:

In Class II laser equipment, your eyes are protected from accidental, short-term exposure to the laser beam by the lid-closing reflex and / or the reflex reaction to turn one's head. This equipment can therefore be used without additional protective measures. Nevertheless, you should not look directly into the laser beam.

The use of operating and adjustment equipment other than that indicated here or the use of other procedures can lead to dangerous exposure to radiation.



**LASER RADIATION**  
DO NOT STARE  
INTO BEAM  
LASER CLASS 2

IEC 60825-1:2007

### CAUTION

**LASER RADIATION**  
DO NOT STARE  
INTO BEAM

 630nm - 660nm / <1mW  
**CLASS II LASER PRODUCT**  
CFR 1040.10 AND 1040.11 CFR

**Do not let the unit fall into children's hands!**

The laser goggles enclosed with these units are not safety goggles. They are designed to make the laser light easier to see.



## Care and maintenance

- Dirty lens glass on the beam emitter detracts from the quality of the beam. It should be cleaned with a soft cloth.
- Clean the laser unit with a damp cloth. Do not spray or immerse the unit! Do not use solvents or thinners!

The LAR-250 rotation laser must be handled carefully, in the same way as any precision optical instrument.

## Technical data

|                              |  |
|------------------------------|--|
| Laser type:                  | Red diode laser, wavelength 635 nm   |
| Output:                      | < 1 mW, Laser Class 2<br>to IEC 60825-1:2007   |
| Self-levelling range:        | ca. $\pm 5^\circ$  |
| Levelling accuracy:          | $\pm 0,1$ mm/m / 1/8" over 100ft   |
| Batteries:                   | 2 x 1,5 V Mono cells Alkaline, Size D, LR20  |
| Operating life:              | Approx. 120 hours  |
| Operating temperature range: | 0°C to +50°C / or 32°F to +122°F<br>At temperatures > 50° C (122°F),<br>the unit begins to regulate automatically. |
| Storage temperature range:   | -20 °C to +60 °C / or -4°F to +140°F   |

Subject to technical modifications.

## Guarantee terms and conditions

Stabila provides a guarantee against deficiencies and faults in the assured characteristics because of material or manufacturing faults for a period of 24 months from date of purchase. Any faults will be eliminated at Stabila's own discretion either by repairing or replacing the unit. Stabila accepts no wider claims.

No liability is accepted for any faults due to inappropriate treatment (e.g. damage caused by the unit falling, operation with the wrong voltage or type of current, use of unsuitable current supply sources) or for any autonomous changes made to the unit by the purchaser or a third party.

Also no claims under guarantee are accepted for natural wear and tear or any small faults that do not significantly affect the unit's operation.

Any guarantee claims must be made via the dealer on the duly completed guarantee form (see last page) to be returned with the unit.



- de** Ergänzung zur Garantieerklärung: Die Garantie gilt weltweit.
- en** Addition to warranty declaration: The warranty applies world-wide.
- fr** Complément à la déclaration de garantie : La garantie est valable dans le monde entier.
- it** Aggiunta alla dichiarazione di garanzia: La garanzia ha validità mondiale.
- es** Ampliación de la declaración de garantía: La garantía tiene validez en todo el mundo.
- nl** Aanvulling op de garantieverklaring: De garantie is wereldwijd geldig.
- pt** Acrescento da declaração de garantia: A garantia é válida em todo o mundo.
- no** Supplement til garantierklæringen: Garantien gjelder i hele verden.
- fi** Takuuilmoituksen täydennys: Takuu on voimassa maailmanlaajuisesti.
- da** Supplement til garantierklæring: Garantien gælder internationalt.
- sv** Komplettering till garantiförklaring: Garantin gäller i hela världen.
- tr** Garanti beyanına ek: Garanti, dünya genelinde geçerlidir.
- cs** Doplnění k prohlášení o záruce: Tato záruka platí po celém světě.
- sk** Doplnok k vyhláseniu o záruke: Táto záruka platí celosvetovo.
- pl** Uzupełnienie oświadczenia gwarancyjnego: Gwarancja obowiązuje na całym świecie.
- sl** Dopolnitev garancijske izjave: Garancija velja po vsem svetu.
- hu** A garancianyilatkozat kiegészítése: A garancia világszerte érvényes.
- ro** Supliment la declarația de garanție: Garanția se aplică la nivel mondial.
- ru** Дополнение к гарантийному заявлению: Гарантия действует по всему миру.
- lv** Garantijas saistību papildinājums: Šī garantija ir spēkā visā pasaule.
- et** Garantii lisa: See garantii kehtib kogu maailmas.
- lt** Garantijos papildymas: Garantija galioja visame pasaulyje.
- ko** 보장 진술 추가: 이 보증서는 전 세계에서 적용됩니다.
- zh** 质保声明的补充信息: 该质保全球适用。